

HENRIKSEN HOOKS

HOOKS
HENRIKSEN HOOKS

HLH

LIFERAFT AND RESCUE BOAT HOOKS



U
S
E
R

M
A
N
U
A
L

Rev.: --

M000615

HENRIKSEN

REDUCING OPERATIONAL RISK

Phone: +47 33 37 84 00
hooks@hhenriksen.com
www.henriksenhooks.com

LAUNCH – USED AS LIFERAFT HOOK

- 1** Check the following before launch:
 - the hook is securely attached to the crane wire
 - the release handle is in the closed position
 - the hook element is in closed position
 - the hook is free of any impurities or ice

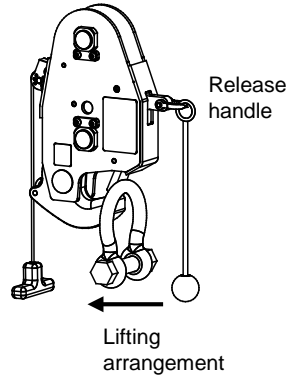

- 2** Place the lifting arrangement properly into the jaw of the hook.

- 3** Start the lowering process with a continuous motion.

- 4** When the liferaft is close to the water surface, pull the red knob at the end of the activation wire. Make sure that the release handle moves to activated / open position and remains there.

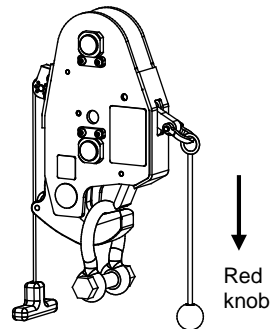

- 5** When the liferaft is waterborne and the hook is off-loaded, the hook will open automatically and release the lifting arrangement.

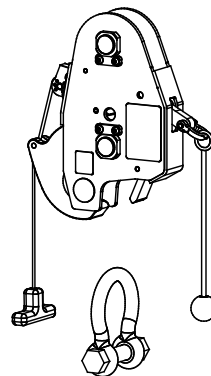

LAUNCH – USED AS RESCUE BOAT HOOK

- 1** Check the following before launch:
 - the hook is securely attached to the crane wire
 - the release handle is in the closed position
 - the hook element is in closed position
 - the hook is free of any impurities or ice
- 2** Place the lifting arrangement properly into the jaw of the hook.
- 3** Start the lowering process with a continuous motion.
- 4** When the boat is close to the water surface, pull the red knob at the end of the activation wire. Make sure that the release handle moves to activated / open position and remains there.
- 5** When the boat is waterborne and the hook is off-loaded, the hook will open automatically and release the lifting arrangement.

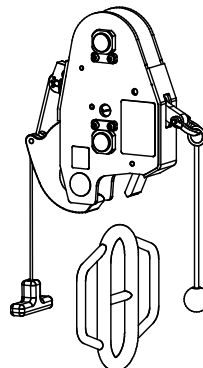
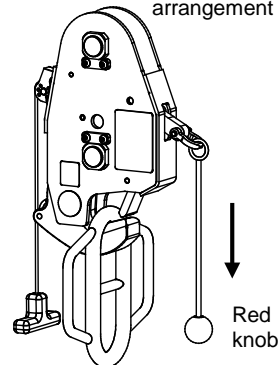
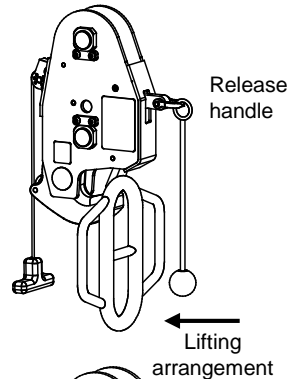

HLH

RESET

- 1** Set the release handle to the closed position, confirmed by a click sound.

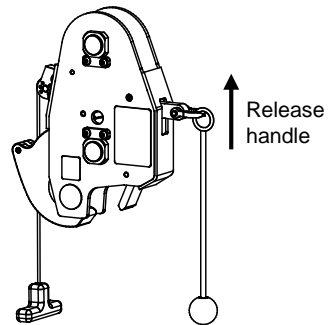

- 2** Set the hook element manually to closed position, confirmed by a click sound.

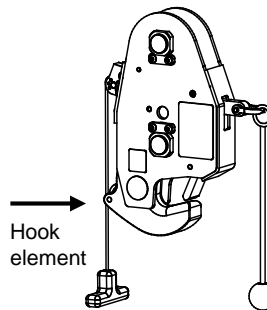

- 3** Make sure that you can clearly see the latch in the inspection hole, refer to the illustration.

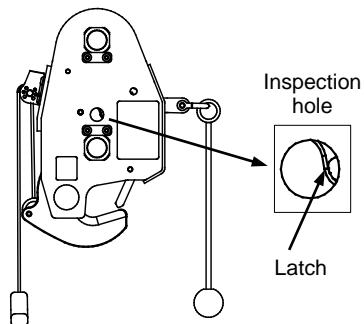

R
E
S
E
T



HLH

RECOVERY

- 1** Make sure that the hook is reset.
Place the lifting arrangement properly into the jaw of the hook.

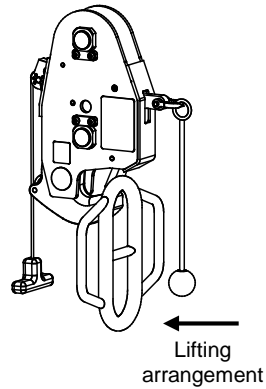

- 2** Make sure that the latch is completely locked, refer to the illustration.
The hook is ready to recover the liferaft or the boat.

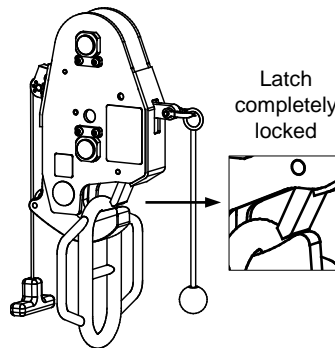

R
E
C
O
V
E
R
Y

LAUNCH WITH MANUAL RELEASE

When the liferaft or the boat is waterborne and the load on the hook is more than 30 kg, the hook will not open (for example there is a strong current).

In this case when the load on the hook is between 30 - 150 kg the manual release must be engaged.

- 1** Make sure that the hook is activated: the release handle is in activated / open position.

- 2** Pull firmly the green grip (with up to 600 – 700 N) to release the hook.

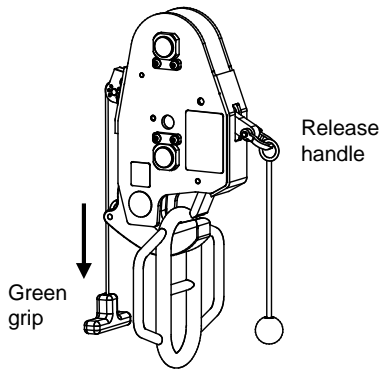

- 3** The hook will open immediately and release the lifting arrangement.

CAUTION: Consider the risk of injury and/or damage the falling slings may cause when the hook opens.

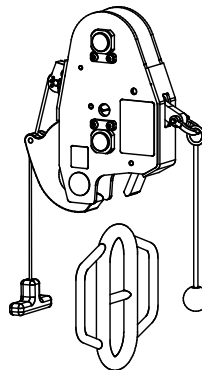

GENERAL CONSIDERATIONS

- 1** We recommend to keep the weight of the hook arrangement as low as possible to ensure a lightweight and safe operation environment.
- 2** We recommend to keep the weight of the lifting arrangement as low as possible to ensure a lightweight and safe operation environment.
- 3** Consider the operational height and the length of the slings, make sure that the hook operator can get access to the hook and operate it easily and safely.
- 4** Consider the risk of injury and/or damage the falling slings may cause when the liferaft / boat gets waterborne under the launch process.
- 5** We recommend to use proper sized rings or lifting arrangements in the jaw of the hook:
 - HLH 1,5: $\varnothing 8 - \varnothing 16$
 - HLH 3,5: $\varnothing 19 - \varnothing 27$
- 6** In case the hook is used as a rescue boat hook we recommend to use standard Henriksen Lifting Rings, because the ring dimensions are designed to **geometrically fit** together with the Henriksen Hooks. See more details in our **HLR** document.

MOUNTING

Mount the hook at the end of the fall wire from the crane or davit.

Henriksen top attachments (shackle) are available.

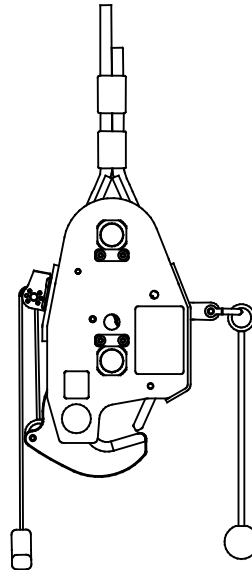

FUNCTIONAL TEST

Do a functional test of the following when testing the hook for the first time:

- The lifting arrangement shall be inserted simply and safely.
- Safe and stable operational conditions for the hook operator
- The operator can safely reach both the red knob and the green grip.
- The hook releases the lifting arrangement once the liferaft or the boat gets waterborne.
- The manual release is working when the hook is still loaded after the liferaft or the boat gets waterborne.

We recommend to remove ice with a rubber hammer if necessary.



HLH

- 1** For safety reasons carry out the control in good lighting conditions.
- 2** Remove all impurities (salt, grease, dust, etc.) with fresh water. Remove ice with a rubber hammer if necessary.
- 3** Check that the following parts are free from deformations and defects:

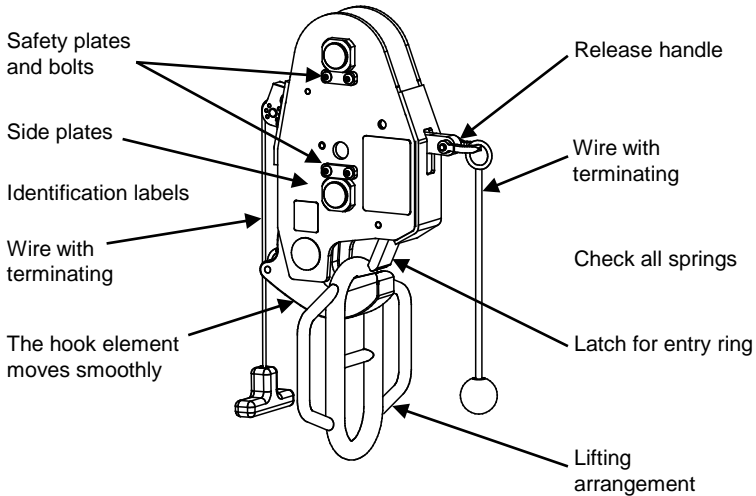
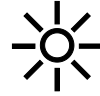

- 4** Do a functional test of the following :
 - The hook element can open fully.
 - The lifting arrangement shall be inserted simply and safely.
 - The release mechanism operates as expected.

- 5** DO NOT PAINT ANY PART OF THE HOOK!



Contact the manufacturer in case of any deviation!



HLH

SAFE LAUNCH – USED AS LIFERAFT HOOK

- 1** The hook operator connects the lifting arrangement before launch, and then gives a signal to the crane operator that the lowering process can start.

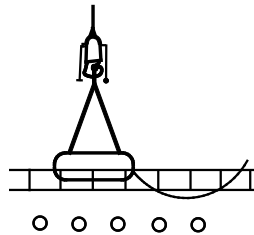

- 2** The crane operator starts the lowering process with a continuous motion.

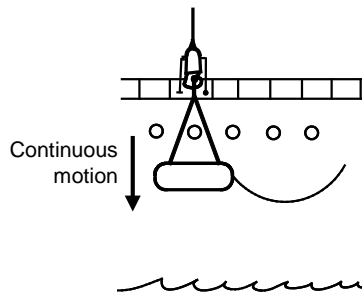

- 3** The operators make sure that there are no obstacles under the liferaft. The hook operator then activates the hook when the liferaft is close to the water surface.

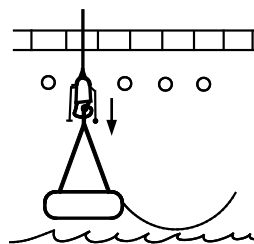

S
A
F
E

U
S
E

SAFE LAUNCH – USED AS LIFERAFT HOOK

- 4 The hook operator takes a safe stand-by position.

- 5 When the liferaft gets waterborne and the hook is off-loaded, the hook will open automatically and release the lifting arrangement.
CAUTION: Consider the risk of injury and/or damage the falling slings may cause when the liferaft gets waterborne under the launch process.

- 6 The crane operator lifts the hook to avoid collision with the liferaft or the crew.

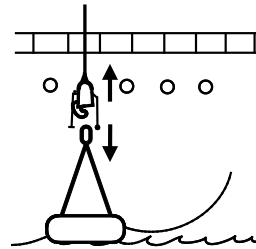



SAFE LAUNCH – USED AS RESCUE BOAT HOOK

1 The hook operator connects the lifting arrangement and the painter line before launch, and then gives a signal to the crane operator that the lowering process can start.

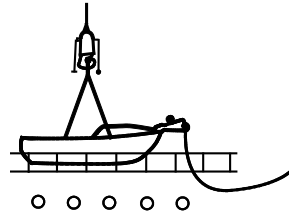

2 The crane operator starts the lowering process with a continuous motion.

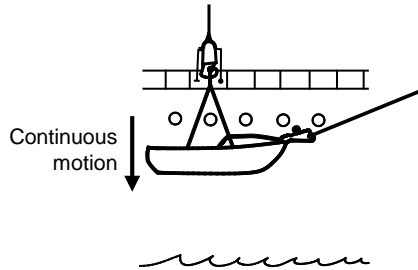

3 The operators make sure that there are no obstacles under the boat.

The hook operator then activates the hook when the boat is close to the water surface.

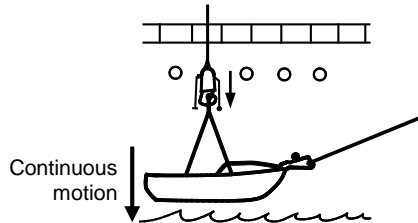

4 The hook operator stands back and takes a safe stand-by position.



SAFE LAUNCH – USED AS RESCUE BOAT HOOK

- 5** When the boat gets waterborne and the crane hook is off-loaded, the hook will open automatically and release the lifting arrangement.

CAUTION: Consider the risk of injury and/or damage the falling slings may cause when the rescue boat gets waterborne under the launch process.

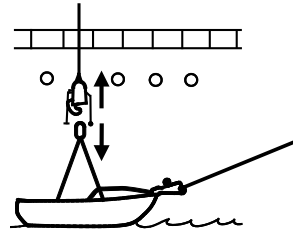

- 6** The crane operator lifts the crane hook to avoid collision with the boat or the crew.

- 7** The coxswain or the hook operator releases the painter line when the boat and the crew is ready.

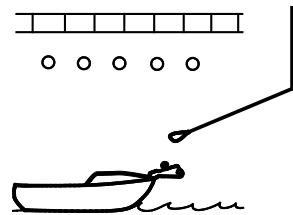

- 8** The coxswain maneuvers the boat ahead and away from the vessel.

S
A
F
E

U
S
E



HLH

SAFE RECOVERY - USED AS RESCUE BOAT HOOK

- 1** The vessel crew make sure that the hook is reset and securely attached to the crane wire.
The hook operator makes sure that the lifting arrangement on the boat is ready and that the painter hook is reset.

- 2** The coxswain maneuvers the boat close to the vessel to let the hook operator safely get the painter line.

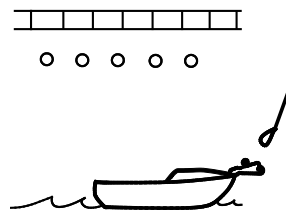

- 3** The hook operator connects the painter line.

- 4** The coxswain reduces the speed of the boat to get in the correct position below the hook.

The hook operator takes a safe operating position.

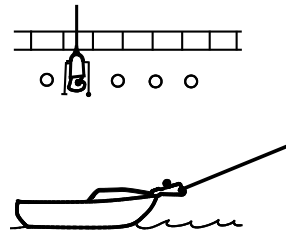

- 5** The crane operator lowers the hook to let the hook operator safely get it.

The hook operator gives a signal to the crane operator when the hook is in the correct operational position.

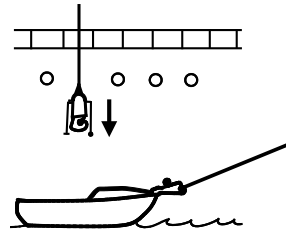

S
A
F
E

U
S
E



HLH

SAFE RECOVERY - USED AS RESCUE BOAT HOOK

- 6** The hook operator connects the lifting arrangement, and gives a signal to the crane operator.
The crane operator starts the automatic tensioning system (if available) to give tension in the wire.

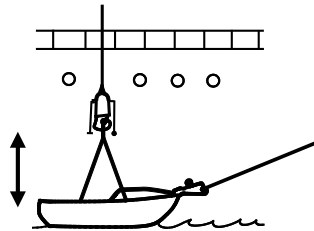

- 7** The hook operator stands back and takes a safe stand-by position.

- 8** The crane operator starts the lifting process with a smooth motion as the boat moves upwards on a wave.

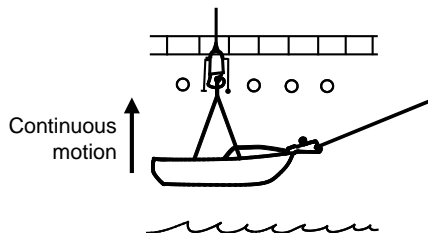

- 9** The crane operator completes the lifting process with a continuous motion and places the boat into the crib.

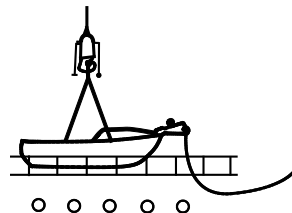

S
A
F
E

U
S
E