

HENRIKSEN HOOKS

**HOOKS**  
HENRIKSEN HOOKS

# HMKTWEA

REMOTE RELEASE OFF-LOAD HOOKS

TWIN SYSTEM



U  
S  
E  
R  
  
M  
A  
N  
U  
A  
L

Rev.: --

M000301

**HENRIKSEN**

REDUCING OPERATIONAL RISK

Phone: +47 33 37 84 00  
hooks@hhenriksen.com  
www.henriksenhooks.com

## HMKTWEA

### LAUNCH

1 Check that the power supply is on.

2 Check the following on both hooks:

- the hook element is in closed position
- you can clearly see the activation latch in the inspection hole on the master hook, refer to the illustration
- the lifting ring is properly placed
- the toggle switch is in closed position
- the safety pin is **not** inserted into the hook
- the hook is free of any impurities or ice

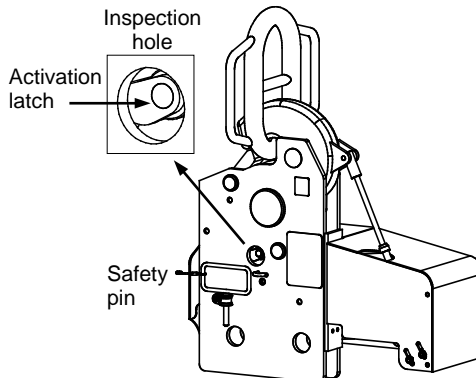
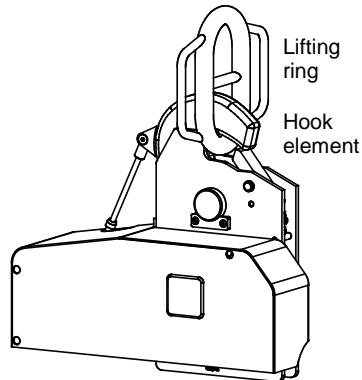

3 Start the lowering process with a continuous motion.

## HMKTWEA

### LAUNCH

- 4** When the boat is close to the water surface set the toggle switch to activated/open position to activate the hooks.

**NOTE:**

Set the toggle switch to closed position to cancel the activated state of the hooks if necessary.

- 5** When the boat is waterborne and **both** hooks are off-loaded, the hooks will open automatically **at the same time** and release the lifting rings.

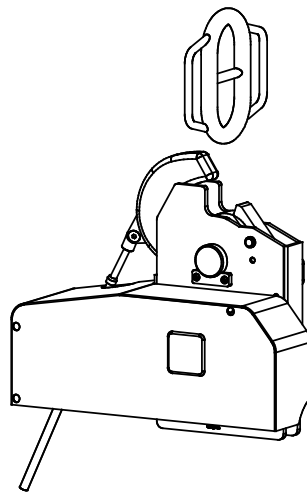

## HMKTWEA

### RESET

- 1 Set the toggle switch to closed position to drive the actuator to the closed position.

The hook elements move to closed position on both hooks.

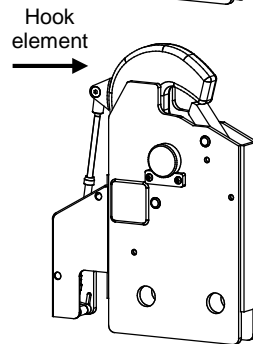
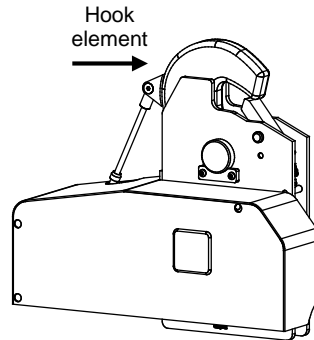

- 2 Make sure that you can clearly see the activation latch in the inspection hole on the master hook, refer to the illustration.

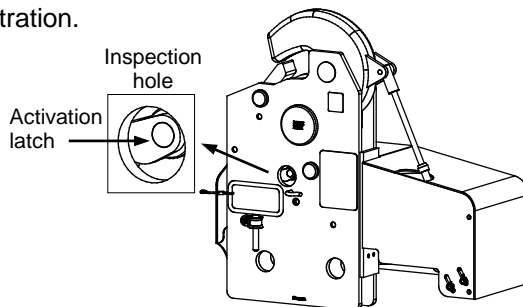

R  
E  
S  
E  
T

## HMKTWEA

### RECOVERY

**1** Make sure that the hooks are reset.

**2** Place the lifting ring properly into the jaw of the forward hook and make sure that the latch is completely locked, refer to the illustration.

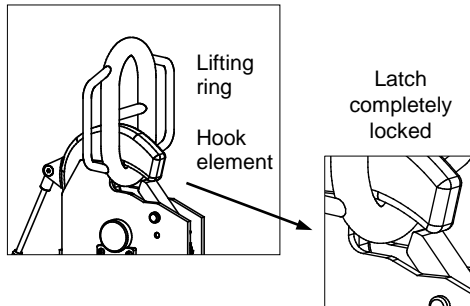

**3** Place the second lifting ring properly into the jaw of the aft hook and make sure that the latch is completely locked, refer to the illustration.

**4** The hooks are ready to recover the boat.

R  
E  
C  
O  
V  
E  
R  
Y

## HMKTWEA

### MANUAL OVERRIDE

The hooks can be operated manually in case of:

- electrical failure (when the twin control system is still operative)
- damage of the push/pull cable system (when the twin control system is not operative)

The launch and the reset processes are different in these cases, however the recovery process is the same as in the normal operation mode.

### GENERAL PREPARATION BEFORE MANUAL OVERRIDE

- 1** Remove 3 pcs. screws from the cover of the actuator on the master hook.

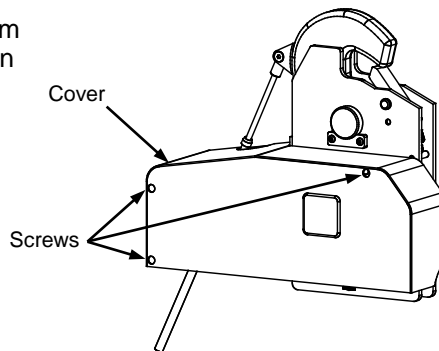

- 2** Remove the cover of the actuator on the master hook.

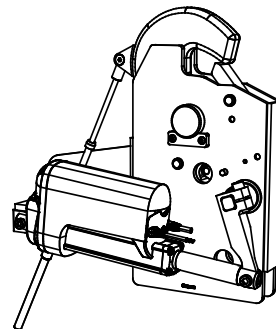

# HMKTWEA

## GENERAL PREPARATION BEFORE MANUAL OVERRIDE

- 3** Remove the screws from the actuator on the master hook.

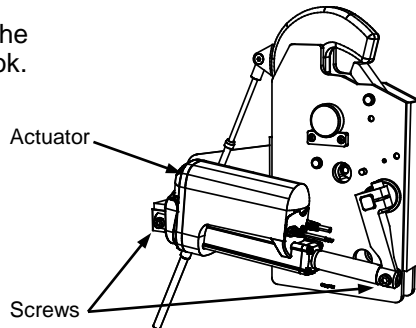

- 4** Remove the actuator on the master hook.

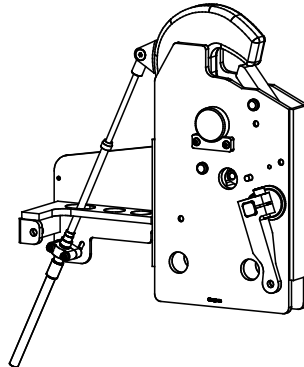

## HMKTWEA

### ELECTRICAL FAILURE

### ADDITIONAL PREPARATION BEFORE MANUAL OVERRIDE

- 1 Set the hook element manually to closed position and hold it in this position on the master hook, and check that the hook element moves to closed position on the slave hook at the same time.

Then turn the actuator arm on the master hook counter-clockwise to the closed position to properly lock the hook elements, refer to the illustration.

- 2 Release the hook element and keep holding the actuator arm in the closed position.

- 3 Insert the safety pin into the master hook.

Make sure that the safety pin is properly placed, refer to the illustration.

- 4 Release the actuator arm.

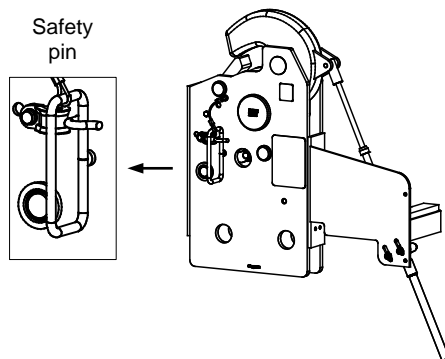
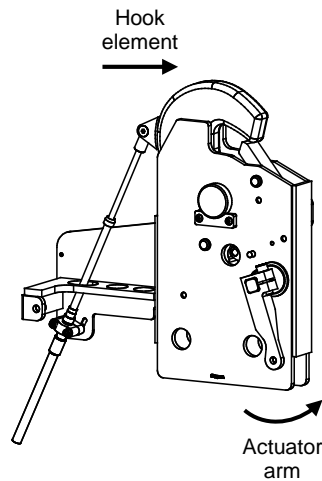



# HMKTWEA

## ELECTRICAL FAILURE LAUNCH

- 1 Check the following on the master hook:
  - the actuator is disconnected
  - the hook element is in closed position
  - the safety pin is properly placed
  - you can clearly see the activation latch in the inspection hole, refer to the illustration
  - the lifting ring is properly placed
  - the hook is free of any impurities or ice

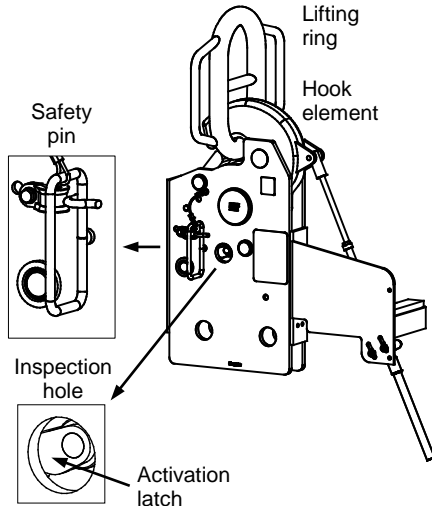

- 2 Check the following on the slave hook:
  - the hook element is in closed position
  - The safety pin is **not** inserted into the hook
  - the lifting ring is properly placed
  - the hook is free of any impurities or ice

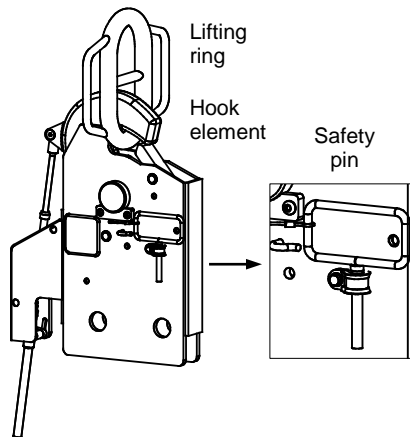

## HMKTWEA

### ELECTRICAL FAILURE LAUNCH

- 3 Start the lowering process with a continuous motion.
- 4 When the boat is close to the water surface, twist the safety pin clockwise and pull it out from the master hook.
- 5 Turn the actuator arm clockwise against the push/pull cable and hold it in the end position, refer to the illustration.
- 6 When the boat is waterborne and **both** hooks are off-loaded, the hooks will open immediately **at the same time** and release the lifting rings.
- 7 Release the actuator arm.

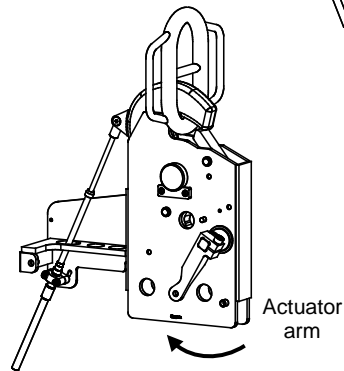
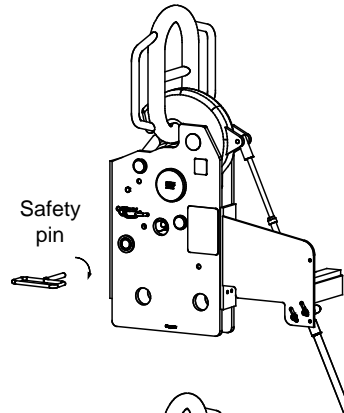

## HMKTWEA

### ELECTRICAL FAILURE RESET

- 1** Check that the actuator is disconnected on the master hook.
- 2** Set the hook element manually to closed position on the master hook, and check that the hook element moves to closed position on the slave hook at the same time.

Then turn the actuator arm on the master hook counter-clockwise to the closed position and hold it in this position to properly lock the hook element, refer to the illustration.

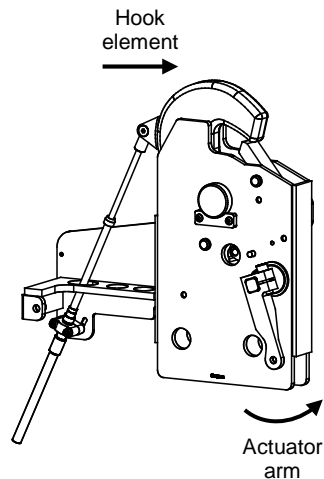

## HMKTWEA

### ELECTRICAL FAILURE RESET

- 3** Insert the safety pin into the master hook.

Make sure that the safety pin is properly placed, refer to the illustration, and release the actuator arm.

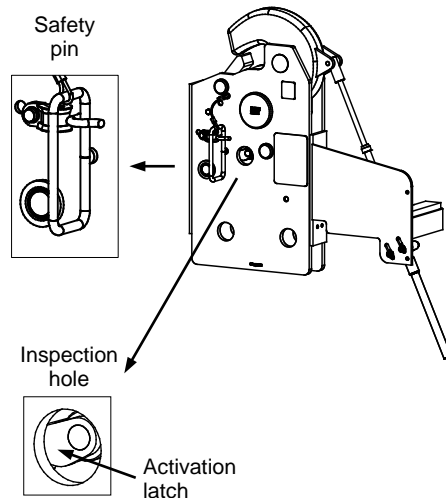

- 4** Make sure that you can clearly see the activation latch in the inspection hole on the master hook, refer to the illustration.

- 5** The hooks are ready to recover the boat.

## HMKTWEA

## DAMAGE OF THE PUSH/PULL CABLE SYSTEM

ADDITIONAL PREPARATION  
BEFORE MANUAL OVERRIDE

- 1 Remove the countersunk screws on both hooks and disconnect the push/pull cable, refer to the illustration.

**CAUTION:**

Be aware that the hook elements can suddenly move into the open position when you remove the screw, this may cause damage or injury!

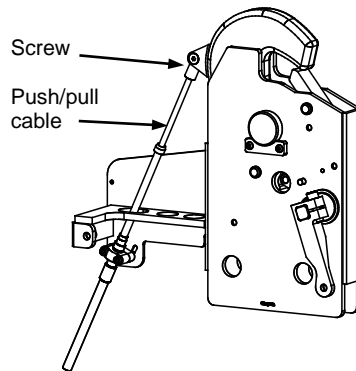

- 2 Set the hook element on the master hook manually to closed position and hold it in this position.

Then turn the actuator arm on the master hook counter-clockwise to the closed position to properly lock the hook element, refer to the illustration.

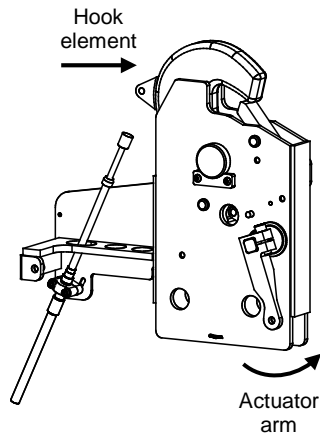

# HMKTWEA

## DAMAGE OF THE PUSH/PULL CABLE SYSTEM

### ADDITIONAL PREPARATION BEFORE MANUAL OVERRIDE

**3** Keep holding the actuator arm in the closed position and release the hook element.

**4** Insert the safety pin into the master hook.  
Make sure that the safety pin is properly placed, refer to the illustration.

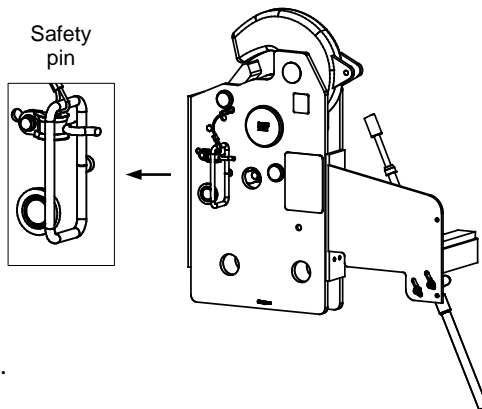

**5** Release the actuator arm.

## HMKTWEA

### DAMAGE OF THE PUSH/PULL CABLE SYSTEM

### ADDITIONAL PREPARATION BEFORE MANUAL OVERRIDE

**6** Set the hook element on the slave hook manually to closed position and hold it in this position.

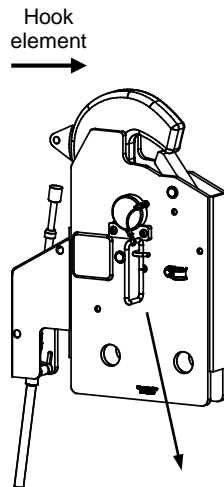

**7** Insert the safety pin into the slave hook.  
Make sure that the safety pin is properly placed, refer to the illustration.

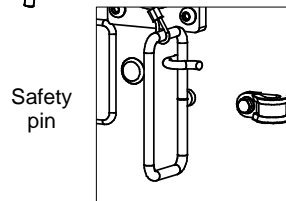

**8** Release the hook element.

# HMKTWEA

## DAMAGE OF THE PUSH/PULL CABLE SYSTEM LAUNCH

- 1** Check the following on the master hook:
- the actuator is disconnected
  - the push/pull cable is disconnected
  - the hook element is in closed position
  - the safety pin is properly placed
  - you can clearly see the activation latch in the inspection hole, refer to the illustration
  - the lifting ring is properly placed
  - the hook is free of any impurities or ice

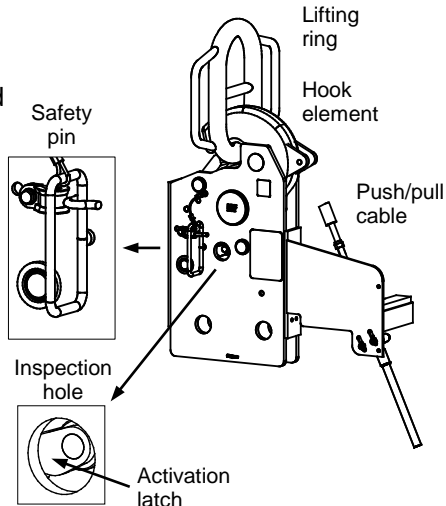

- 2** Check the following on the slave hook:
- the push/pull cable is disconnected
  - the hook element is in closed position
  - the safety pin is properly placed
  - the lifting ring is properly placed
  - the hook is free of any impurities or ice

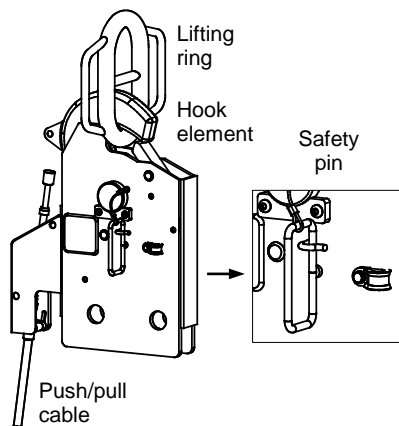



# HMKTWEA

## DAMAGE OF THE PUSH/PULL CABLE SYSTEM LAUNCH

- 3** Start the lowering process with a continuous motion.
  
- 4** When the boat is waterborne and **both** hooks are off-loaded activate and open the aft hook first:
  - twist the safety pin clockwise and pull it out, and the hook will open immediately and release the aft lifting ring.
  
- 5** Activate and open the forward hook:
  - twist the safety pin clockwise and pull it out, and the hook will open immediately and release the forward lifting ring.

# HMKTWEA

## DAMAGE OF THE PUSH/PULL CABLE SYSTEM RESET

**1** Follow the steps 2 – 8 in the “**Damage of the push/pull cable system - Additional preparation before manual override**” section to reset the hooks.

**2** The hooks are ready to recover the boat.

## HMKTWEA

## GENERAL CONSIDERATIONS

- 1 We recommend that the hooks are mounted facing in the same direction.

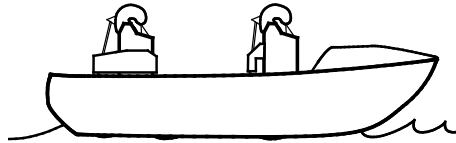

- 2 Consider the ergonomical details before mounting the components of the twin system. It shall be easy to install, remove, and safe to operate and inspect the hooks, the twin control box and the toggle switch.
- 3 Place the twin control box in the middle between the hooks to ensure almost the same cable length for the push/pull cables.
- 4 Consider correct drainage and protection against water ingress before mounting of the twin control box.
- 5 Use an installation path for the cables that prevents tripping hazard, and protect the cables against wear and tear.
- 6 Make sure that the minimum bending radius of the push/pull cables will be more than 200 mm / 8 inch after the cable are installed.
- 7 Consider prevention against icing on the twin control box and the hooks.
- 8 We strongly recommend to use standard Henriksen Lifting Rings, because the ring dimensions are designed to **geometrically fit** together with the Henriksen Hooks.

## HMKTWEA

### MECHANICAL

- 1 Place the hooks between the plates of the lifting arrangement of the boat.

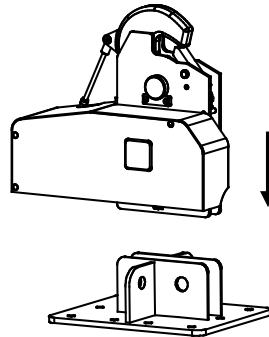

- 2 Insert the mounting bolts through the holes on the lifting arrangement and the hook.

**WARNING:**

Use M30 bolts with minimum A4-70 quality.

The bolt should be unthreaded in the lifting cross-section.

The length is specified by the boat builder.

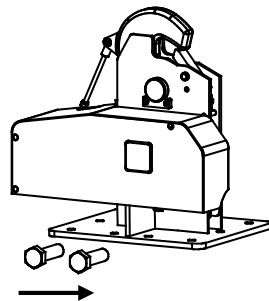

- 3 Mount the locknuts.

**WARNING:**

Use M30 locknuts and maximum 70 Nm torque.

Always use new locknuts.

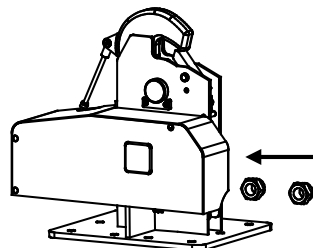



## HMKTWEA

### MECHANICAL

- 4 Mount the twin control box with the push/pull cables. Refer to the illustration for dimensions and hole positions.

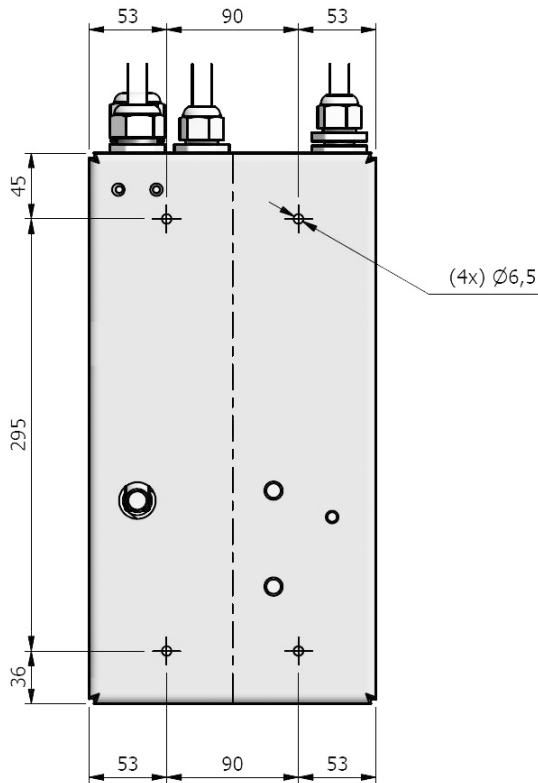

## HMKTWEA

### MECHANICAL

- 5** The twin control box is usually delivered with the cables installed. In case the cables need to be (re-)installed, check that the cables are mounted in the same position, refer to the illustration.



- 6** Set the actuator in extracted position (open the hook) on the master hook. The slave hook is already in open position when the cable is not installed.

## HMKTWEA

### MECHANICAL

- 7** Connect the cables to the hook elements and secure the cables with the clamps on the hooks.



- 8** Extract the actuator to check that the cables can move beyond the end position in the closed positions of the hooks:
- there is a gap between the dust cover and the nut on the ends of the cables in the twin control box, refer to the illustration.

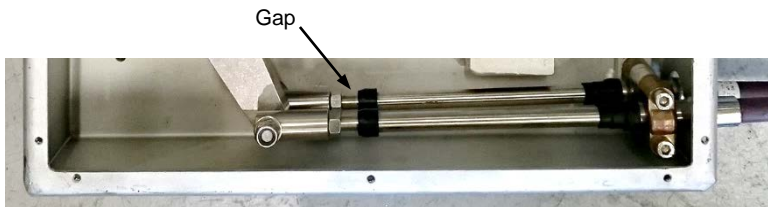

## HMKTWEA

### MECHANICAL

- 8** Retract the actuator to check that the cables can move beyond the end position in the open positions of the hooks:
- there is a gap between the dust cover and the nut on the cable ends on the hook side of the cables, refer to the illustration.

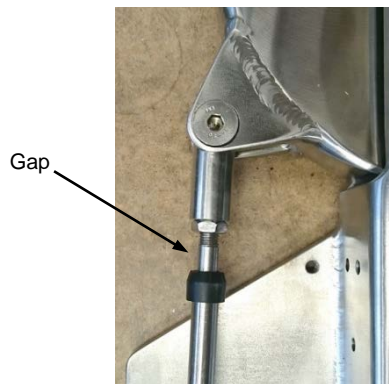

- 9** Close the hooks (extract the actuator) and check that the position of the hook elements are synchronized, refer to the illustration.



Master hook



Slave hook



## HMKTWEA

### MECHANICAL

- 10** Adjust the position of the hook element on the slave hook if necessary:
- open the hooks and adjust the position of the cable connection at the hook element or the position of the clamp on the hook, refer to the illustration
  - close the hooks and check the position of the hook elements
  - continue to adjust the position of the hook elements if necessary

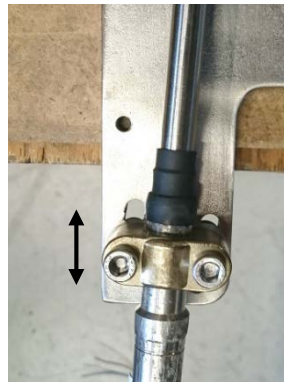

- 11** Test the hooks with load, when the hooks are mounted:
- both hook elements shall move a little beyond the closed position when loaded

Adjust the position of the cable connection(s) or the position of the clamp(s) on the hook(s) if necessary.

**CAUTION:** Remember to open the hooks before any adjustment.

# HMKTWEA

## ELECTRICAL

**1** Refer to the following illustrations for dimensions and hole positions of the electrical components to install. Use correct type of screws (depending on the board material) to fasten the components.

- Motor drive (C1):

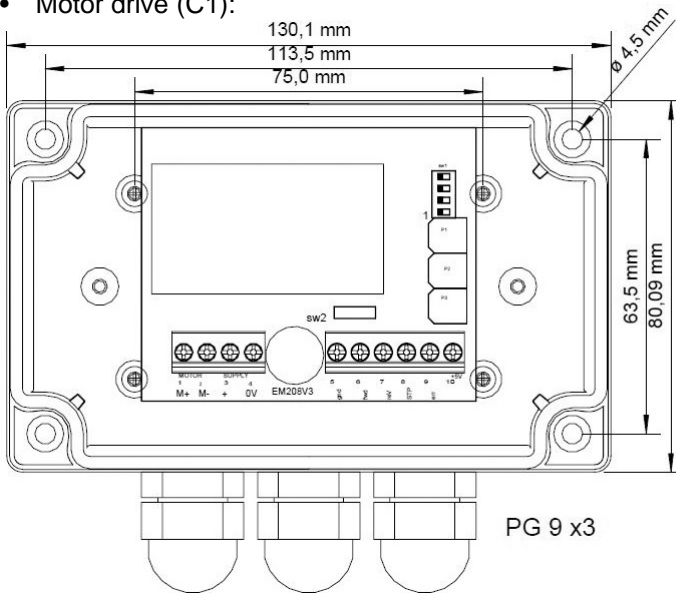

- Enclosure (E1) for toggle switch (optional parts)

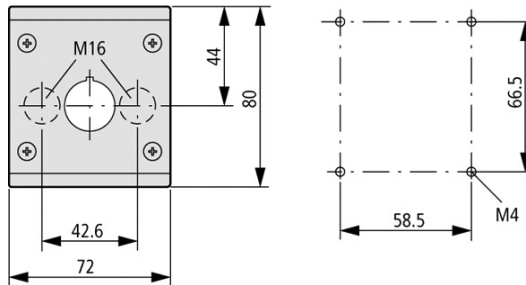

# HMKTWEA

## ELECTRICAL

**2** Connect the electrical cables, refer to the connection diagram below.

ID	Description
M	Actuator
S1	Toggle switch * **
C1	Motor drive
E1	Enclosure IP66 *
W1	Cable 3 x 1,5 *
W2	Cable gland M16 *
W3	Cable 2 x 2,5 (6 m)

\* Optional parts

\*\* Toggle switch with marked activated/open and closed positions

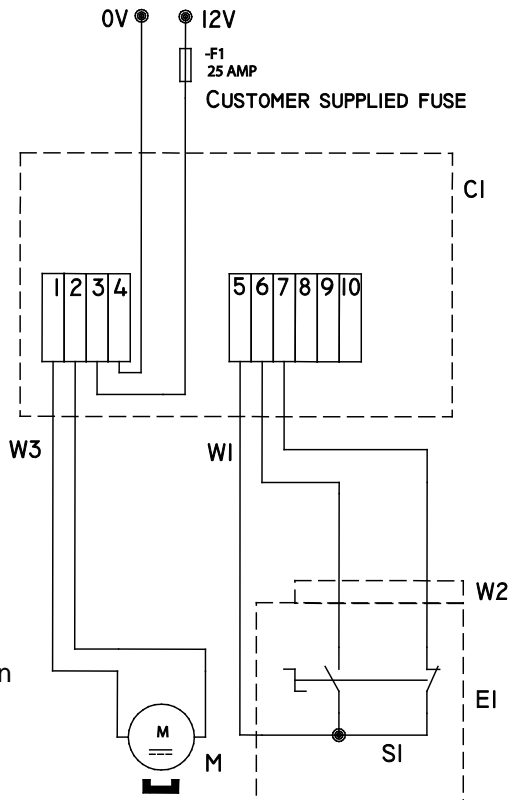

## HMKTWEA

### FUNCTIONAL TEST

Do a functional test of the following after mounting the hooks, the cables and the electrical components on the boat:

- When both hooks are unloaded, they will open immediately at the same time when you activate/open them.
- Load or simulate the load only on the aft hook and check that the activated hooks will not open until the load is removed.
- Load or simulate the load only the on forward hook and check that the activated hooks will not open until the load is removed.
- The hook elements can open freely.
- The rings can be inserted simply and safely.
- The installation path for the cables does not cause tripping hazard and the cables are protected against wear and tear.
- The safety pins are easy to insert into the hooks.
- The synchronization mechanism can move smoothly in the twin control box. Apply lubricants if necessary.

We recommend to prevent the hook against any ice to build up.



## HMKTWEA

- 1** For safety reasons carry out the control in good lighting conditions.
- 2** Remove all impurities (salt, grease, dust, etc.) with fresh water. Remove ice if necessary.
- 3** Check that the following parts are free from deformations and defects:

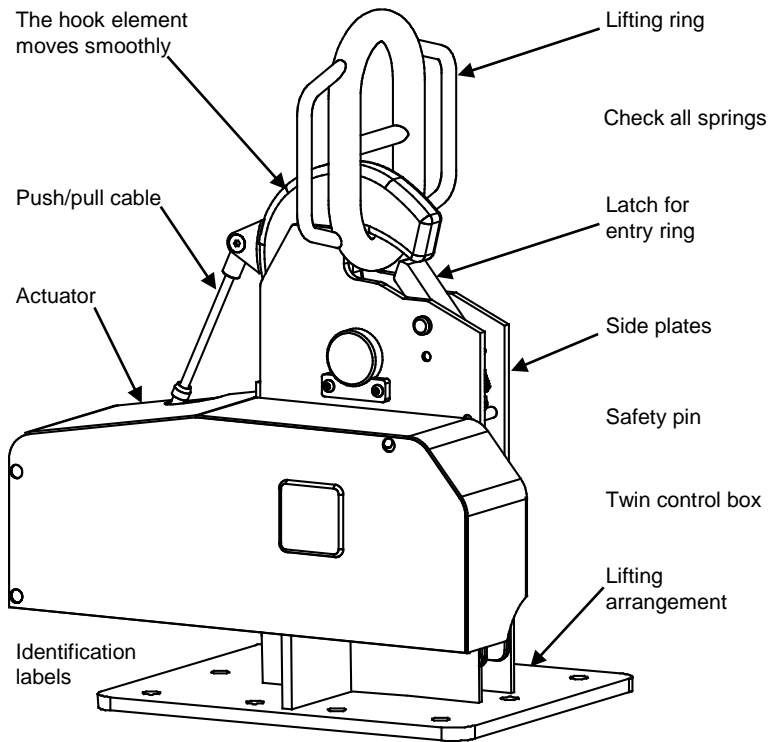
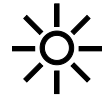

Contact the manufacturer in case of any deviation!

## HMKTWEA

- 4** Do a functional test of the following:
- When both hooks are unloaded, they will open immediately at the same time when you activate/open them.
  - Load or simulate the load only on the aft hook and check that the activated hooks will not open until the load is removed.
  - Load or simulate the load only the on forward hook and check that the activated hooks will not open until the load is removed.
  - The hook elements can open freely.
  - The rings can be inserted simply and safely.
  - The installation path for the cables does not cause tripping hazard and the cables are protected against wear and tear.
  - The safety pins are easy to insert into the hooks.
  - The synchronization mechanism can move smoothly in the twin control box. Apply lubricants if necessary.

We recommend to prevent the hook against any ice to build up.

**5 DO NOT PAINT ANY PART OF THE HOOKS!**



Contact the manufacturer in case of any deviation!

## HMKTWEA

### SAFE LAUNCH

**1** The hook operator connects the lifting rings and the painter line before launch, and then gives a signal to the crane operator that the lowering process can start.

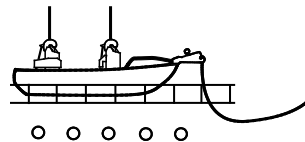

**2** The crane operator starts the lowering process with a continuous motion.

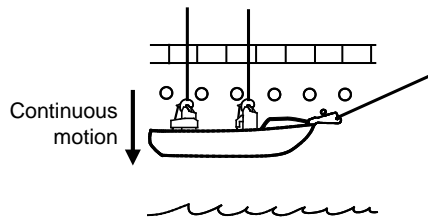

**3** The operators make sure that there are no obstacles under the boat.

The hook operator then activates the lifting hooks when the boat is close to the water surface.

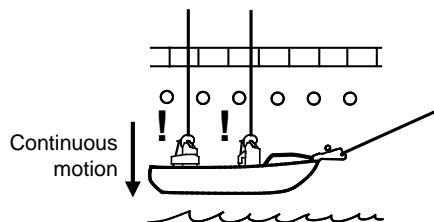

**NOTE:**

In case of manual override follow the instructions as described in the “**Manual Override**” chapter.

**4** The hook operator stands back and takes a safe stand-by position.

S  
A  
F  
E  
  
U  
S  
E



## HMKTWEA

### SAFE LAUNCH

- 5** When the boat gets waterborne and both lifting hooks are off-loaded, the hooks will open automatically and release the lifting rings.

**NOTE:**  
In case of manual override follow the instructions as described in the **“Manual Override”** chapter.

The crane operator lifts the lifting rings to avoid collision with the boat or the crew.

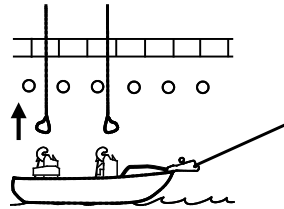

- 6** The coxswain or the hook operator releases the painter line when the boat and the crew is ready.

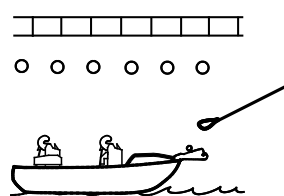

- 7** The coxswain maneuvers the boat ahead and away from the vessel.

S  
A  
F  
E  
  
U  
S  
E





## HMKTWEA

### SAFE RECOVERY

**1** The hook operator makes sure that both the lifting hooks and the painter hook are reset.

**2** The coxswain maneuvers the boat close to the vessel to let the hook operator safely get the painter line.

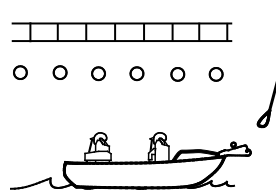

**3** The hook operator connects the painter line.

**4** The coxswain reduces the speed of the boat to get in the correct position below the lifting rings.

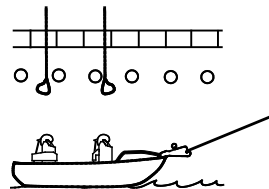

**5** The crane operator lowers the lifting rings to let the hook operator safely get them.

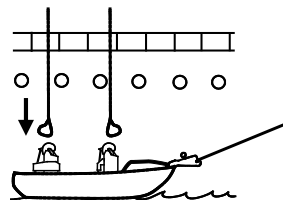

S  
A  
F  
E  
  
U  
S  
E



## HMKTWEA

### SAFE RECOVERY

- 6** The hook operator connects the lifting rings first to the forward, then to the aft hook, and gives a signal to the crane operator.

The crane operator starts the automatic tensioning system (if available) to give tension in the wire.

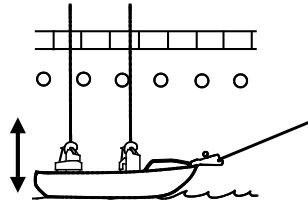

- 7** The hook operator stands back and takes a safe stand-by position.

- 8** The crane operator starts the lifting process with a smooth motion as the boat moves upwards on a wave.

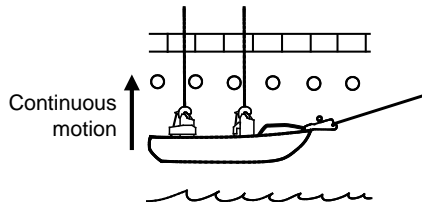

- 9** The crane operator completes the lifting process with a continuous motion and places the boat into the crib.

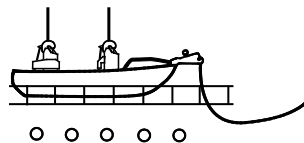

S  
A  
F  
E  
  
U  
S  
E