

HENRIKSEN HOOKS



# HRH

RIB HOOK

U  
S  
E  
R  
  
M  
A  
N  
U  
A  
L



Rev.: --

M000484



REDUCING OPERATIONAL RISK

Phone: +47 33 37 84 00  
hooks@hhenriksen.com  
www.henriksenhooks.com

## HRH

### LAUNCH

- 1** Check the following before launch:
  - the hook element is in closed position
  - the reset knob is in the closed position
  - the lifting ring is properly placed
  - the hook is free of any impurities or ice
- 2** Start the lowering process with a continuous motion.
- 3** When the boat is close to the water surface, pull the ball at the end of the activation wire. Make sure that the reset knob moves to open (activated) position.
- 4** When the boat is waterborne and the hook is off-loaded, the hook will open automatically and release the lifting ring.

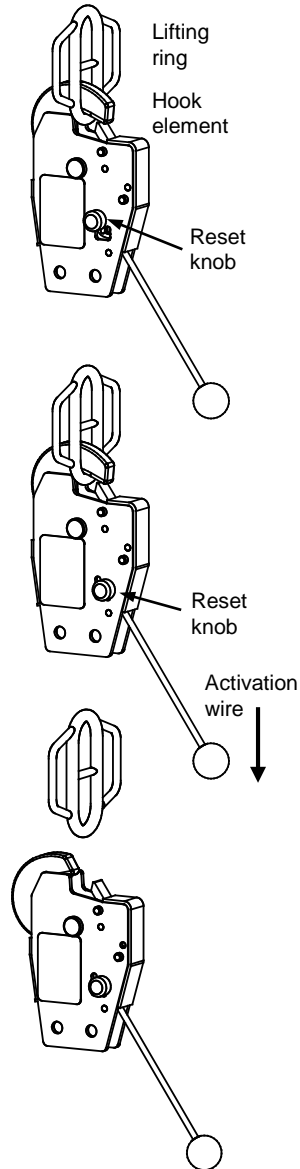

L  
A  
U  
N  
C  
H

## HRH

### RESET

- 1** Set the reset knob to the closed position, confirmed by a click sound.

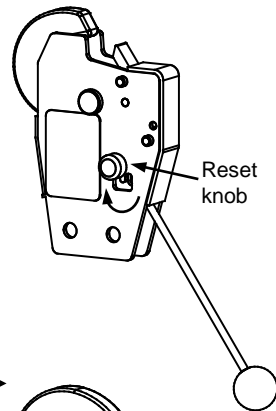

- 2** Set the hook element manually to closed position, confirmed by a click sound.

Make sure that the reset knob is properly in the closed position.

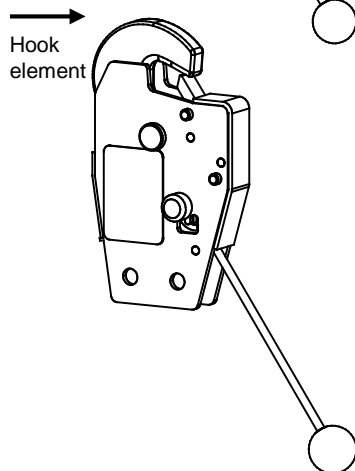

R  
E  
S  
E  
T

## HRH

### RECOVERY

- 1** Make sure that the hook is reset.  
Place the lifting ring properly into the jaw of the hook.

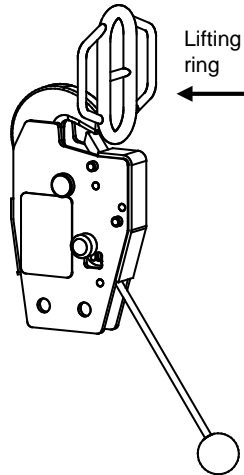

- 2** Make sure that the latch is completely locked, refer to the illustration.  
The hook is ready to recover the boat.

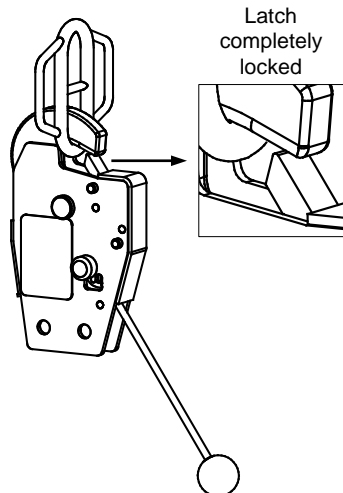

R  
E  
C  
O  
V  
E  
R  
Y

## HRH

## GENERAL CONSIDERATIONS

- 1 Consider the position of the hook before mounting it on the boat. The hook shall be placed over the center of gravity. The load going through it shall be as straight and symmetrical as possible during the **whole** lifting operation.

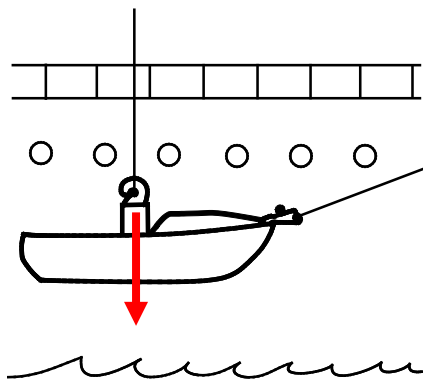

- 2 Make sure that the hook operator can get access to the hook easily, and can operate the hook and connect the lifting ring safely.
- 3 Consider prevention against icing on the hook.
- 4 We strongly recommend to use standard Henriksen Lifting Rings, because the ring dimensions are designed to **geometrically fit** together with the Henriksen Hooks. See more details in our **HLR** document.
- 5 We offer standard Henriksen Bolt Sets and Shims for mounting. See more details in our **Bolt Set** and **Shims** documents.

## HRH

- 1 Place the hook between the plates of the lifting arrangement of the boat.

We recommend:

- to use two outside mounting plates if possible
- to apply shims to reduce the gap between the mounting plates and the hook.

Check that the hook is in the preferred direction.

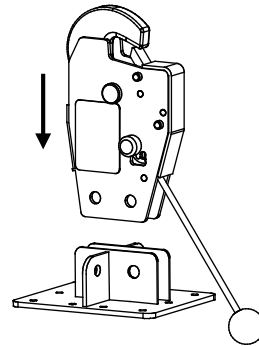

- 2 Insert the mounting bolts through the holes on the lifting arrangement and the hook.

**WARNING:**

Use M12 bolts with minimum A4-70 quality.

The bolt should be unthreaded in the lifting cross-section.

The length is specified by the boat builder.

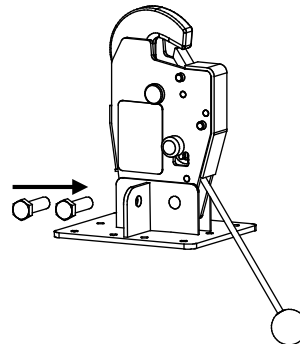

- 3 Mount the locknuts.

We recommend to hold the hook in lifted position when tightening the locknuts.

**WARNING:**

Use M12 locknuts and maximum 40 Nm torque.

Always use new locknuts.

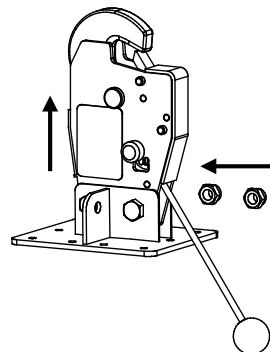

## HRH

### FUNCTIONAL TEST

Do a functional test of the following when testing the hook on the boat for the first time:

- The hook element can open fully.
- The ring shall be inserted simply and safely.
- The unloaded hook opens immediately when you activate it by pulling the activation wire.
- The hook is loaded as straight and symmetrical as possible during the **whole** lifting operation.



## HRH

**1** For safety reasons carry out the control in good lighting conditions.



**2** Remove all impurities (salt, grease, dust, etc.) with fresh water. Remove ice if necessary.



**3** Check that the following parts are free from deformations and defects:

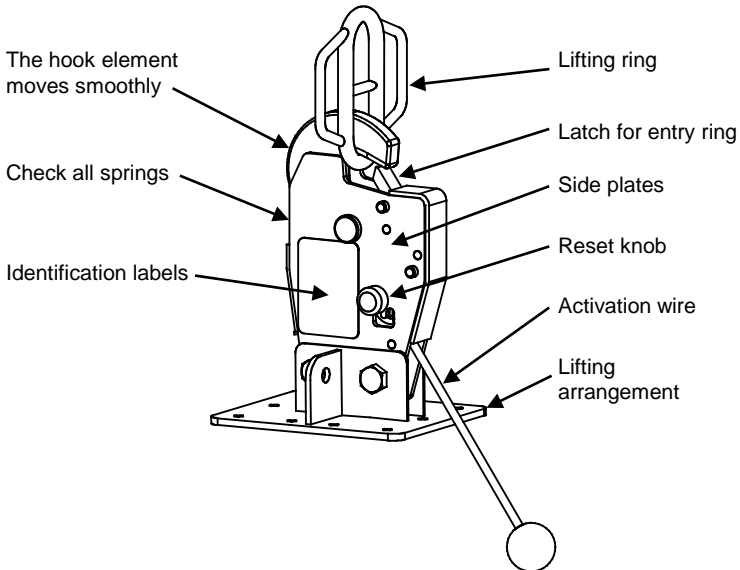

Contact the manufacturer in case of any deviation!



## HRH

- 4** Do a functional test of the following :
- The hook element can open fully.
  - The ring shall be inserted simply and safely.
  - The unloaded hook opens immediately when the you activate it by pulling the activation wire.
  - The hook is loaded as straight and symmetrical as possible during the **whole** lifting operation.

**5 DO NOT PAINT ANY PART OF THE HOOK!**



Contact the manufacturer in case of any deviation!

## HRH

### SAFE LAUNCH

**1** The hook operator connects the lifting ring and the painter line before launch, and then gives a signal to the crane operator that the lowering process can start.

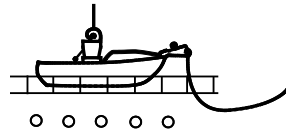

**2** The crane operator starts the lowering process with a continuous motion.

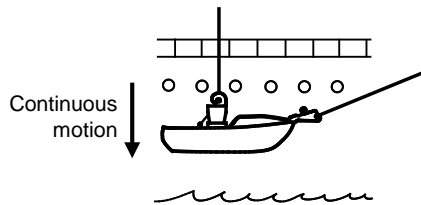

**3** The operators make sure that there are no obstacles under the boat.

The hook operator then activates the lifting hook when the boat is close to the water surface.

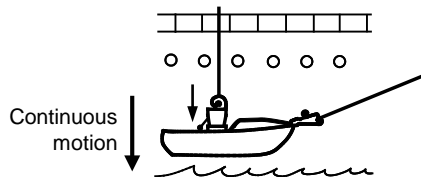

**4** The hook operator stands back and takes a safe stand-by position.

S  
A  
F  
E  
  
U  
S  
E

## HRH

### SAFE LAUNCH

- 5** When the boat gets waterborne and the lifting hook is off-loaded, the hook will open automatically and release the lifting ring.
- The crane operator lifts the lifting ring to avoid collision with the boat or the crew.

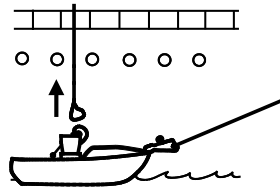

- 6** The coxswain or the hook operator releases the painter line when the boat and the crew is ready.

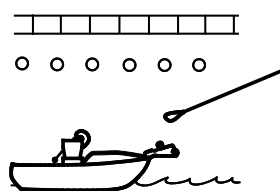

- 7** The coxswain maneuvers the boat ahead and away from the vessel.

S  
A  
F  
E  
  
U  
S  
E



## HRH

### SAFE RECOVERY

**1** The hook operator makes sure that both the lifting hook and the painter hook are reset.

**2** The coxswain maneuvers the boat close to the vessel to let the hook operator safely get the painter line.

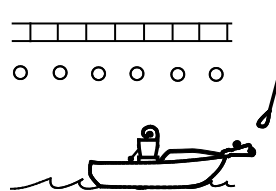

**3** The hook operator connects the painter line.

**4** The coxswain reduces the speed of the boat to get in the correct position below the lifting ring.

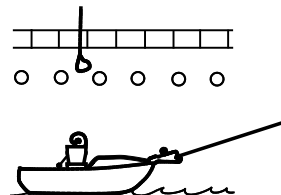

**5** The crane operator lowers the crane hook to let the hook operator safely get it.

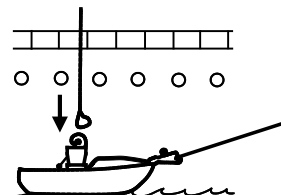

S  
A  
F  
E  
  
U  
S  
E



## HRH

### SAFE RECOVERY

**6** The hook operator connects the lifting ring, and gives a signal to the crane operator.

The crane operator starts the automatic tensioning system (if available) to give tension in the wire.

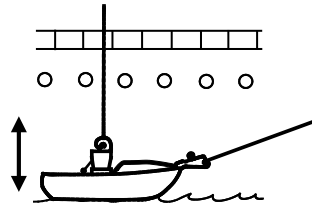

**7** The hook operator stands back and takes a safe stand-by position.

**8** The crane operator starts the lifting process with a smooth motion as the boat moves upwards on a wave.

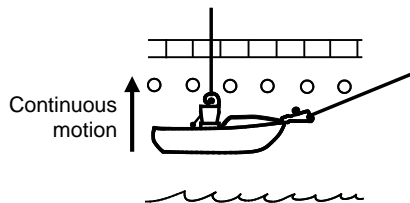

**9** The crane operator completes the lifting process with a continuous motion and places the boat into the crib.

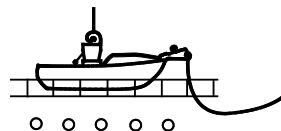

S  
A  
F  
E  
  
U  
S  
E