

RE[®]
BS



Table of Contents

Introduction

About Henriksen, REBS, and Reducing Risk3
 REBS product foundation and product values4

Ladders

Pool Ladder7
 Single stile ladder comparison8
 Tactical Ladder9
 Ultralight Pole Ladder (UPL)11
 Carbon Multi Ladder (CML)14
 Atlas Tactical Ladder System (ATL)23
 Wire Ladder28
 FIFI Ladder Hook30
 Wire Cutter31
 Ladder Reel32
 Rope Ladder34
 Web Ladder35

Hooks

Introduction38
 Pole Release Alternatives39
 Hook Range40
 Carbon Fiber Grapnel Hook43
 MaxGrip Hook44
 Tactical Grapnel Hook45
 Urban Hook47

Poles

Skypole50
 Pole Rail Stand52
 Rolatube53
 Telescopic Pole54
 Windup Pole56
 Giraffe Tracer Pneumatic Pole57

Launchers

REBS Launcher61
 Compact Launcher64

Ascenders

Atlas Powered Ascender APA-568

Climbing

Magnetic Climbing System73

Diving

Scuba Tube76

Special

Transom Adapter78
 Mooring Magnets82
 Rope Climber83
 K9 Insertion Cage84

INTRODUCTION

About Henriksen

H. Henriksen AS is a technology company with a long and proud history within the maritime and offshore sector. The company has a strong position within safe rescue boat lifting operations, Launch & Recovery systems for offshore vessels, Oil Spill Recovery systems and Entering and Boarding Systems for both maritime and urban environments.



Henriksen has a brand vision that is rooted in over 150 years of experience. Our vision has been shaped by our founding fathers and many generations of forefathers. Their first-hand experience and challenges has proven our true overreaching vision over time “always look forward with the intent of creating safer operational conditions.” We are committed to create safer operational conditions world wide and The Henriksen slogan is “Reducing Operational Risk”.

Henriksen was founded in 1856 based in the maritime industry, and is located in South East Norway. We have approximately 45 employees, of whom there are 22 skilled workers, 15 engineers and 5 salespeople.

Henriksen REBS®

The Rapid Entering and Boarding Systems (REBS ®) segment was established at Henriksen in 2003 as a response to a initiative from the Norwegian Defense. They sought products that could increase the effectiveness and safety of boarding

operations. Boarding is a high risk operation and the users wanted equipment that was safe and thoroughly tested. With time REBS has evolved into a result of a multinational cooperation, where input from users in different countries has resulted in product improvements and a reduced operational risk. This development has resulted in several state of the art boarding products.

Boarding operations poses many challenges and the equipment suffers from rough use in demanding environments. The products therefore have to be as lightweight as possible while still being strong and durable. To meet these challenges, we utilize high performance materials like carbon fiber and titanium. We develop and manufacture several products in-house as well as cooperate with other manufacturers of unique high-quality boarding products. We are currently experiencing rapid growth in the REBS® segments and our ambition is to be the unquestionably largest and most competent actor in the world market.

Reducing Operational Risk - Maximizing Operational Performance

The users of REBS® products have their biggest enemy in exposure. We aim to make our products safer, stronger, lighter and faster than any other products in order to maximize the operational performance of our users. Our products allows our users to minimize the level of exposure and thereby reduce their operational risk.

Disclaimer

Although great efforts have been made in order to produce accurate and correct information in this catalog, there is always a possibility that an error has occurred. Designs and dimensions of the products listed in this catalog were correct at the date of publication but are however subject to change without notice. Please ask for our confirmation in cases where accuracy is critical. Typographical and pictorial errors that are brought to our attention will be corrected in subsequent issues.

PRODUCT FOUNDATION

WE SPECIALIZE IN CREATING SYSTEMS AND PRODUCTS

THAT ENABLE OUR USERS TO

FAST, SAFE AND EFFICIENTLY:

Scale ledges

Bridge gaps

Scale surfaces in both

Urban

& Maritime environments

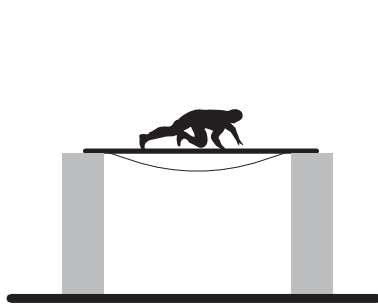

REBS STANDARD

Back in 2016 REBS published the first version of SOCES-2016 (Special Operation Climbing Standard). The standard sets requirements to strength-, design- and environmental-requirements and is a guide for designers, users and purchasers. The lack of relevant military and civil standards inspired us to create SOCES. It combines special operations-requirements with operational- and technical limitations, based on years of experience with Rapid Entering and Boarding Systems (REBS). The standard is open, to be shared to anyone with interest for the subject. Our scope is to make vertical access operations safer, and to be able to compare similar systems to each other, and to create a common tests and understanding. The standard is regularly improved so any comments or improvements is welcome.

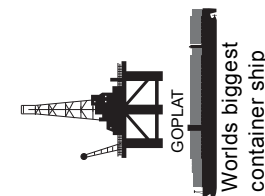
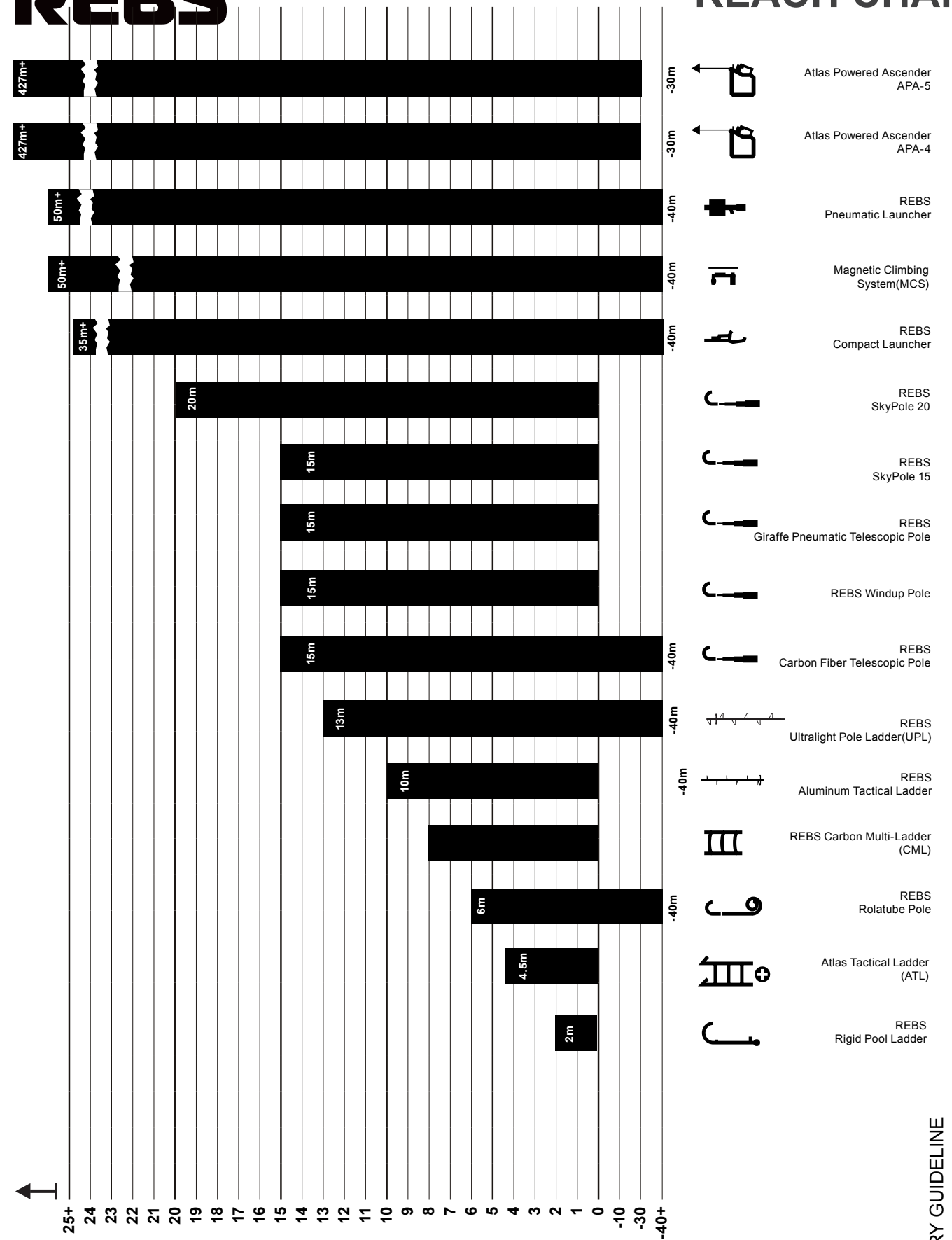

SURFACE/PLASH

GENERAL CATEGORY GUIDELINE

Rigid Ladder 0-4 m
 Section Ladder 2-13 m
 Pole/Hook 3-15 m
 Launcher 10-50 m
 Ascender 5-500 m

LADDERS

REBS®

POOL LADDER

The Pool ladder is a special tool for moderate height boarding operations. The ladder is preferably used together with an optional length wire ladder for extended reach and flexibility. The Pool Ladder can be placed either by hand or using a telescopic pole.

The Pool Ladder is a single section rigid ladder with integrated hooks that offers excellent stability and climbing ease for deployment near entry points. The ladder inside width measures 284 mm. The ladder floats in water and has a MBL of 330 kg. It is recommended for only one operator to climb at a time.

Place a telescopic pole in the lifting funnel to place the Pool Ladder on an entry point far from reach overhead. The lifting funnel is specially made for the top adapter on our telescopic poles and keeps the Ladder from rotating on the Pole, increasing positional control and making the ladder much easier to place securely.

The Pool Ladder is constructed from black anodized high strength aluminum alloy. Standoffs create space for hands and feet while climbing.

In marine environments the wire ladder will provide additional reach as well as increased operational safety. The RIB / boarding vessel will not be able to knock the ladder off its hold when it is riding on the waves.

Specifications

Part no.	BE001690
MBL	330 kg / 728 lbs
Weight	6,2 kg / 13.7 lbs
Material	Black Anodized Aluminum

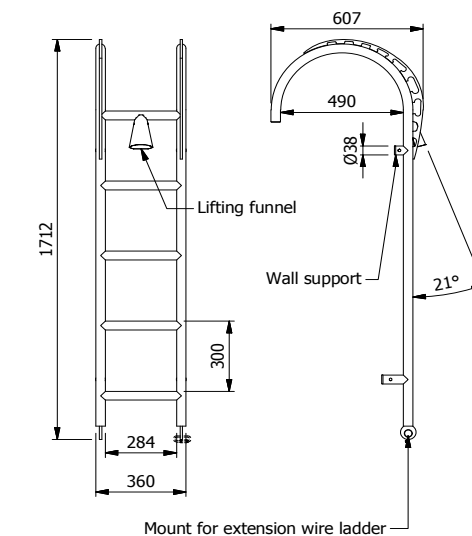

SINGLE STILE LADDER COMPARISON

1. Tension 2. Step 3. Flex 4. Crushing 5. Bending (incl. joint)

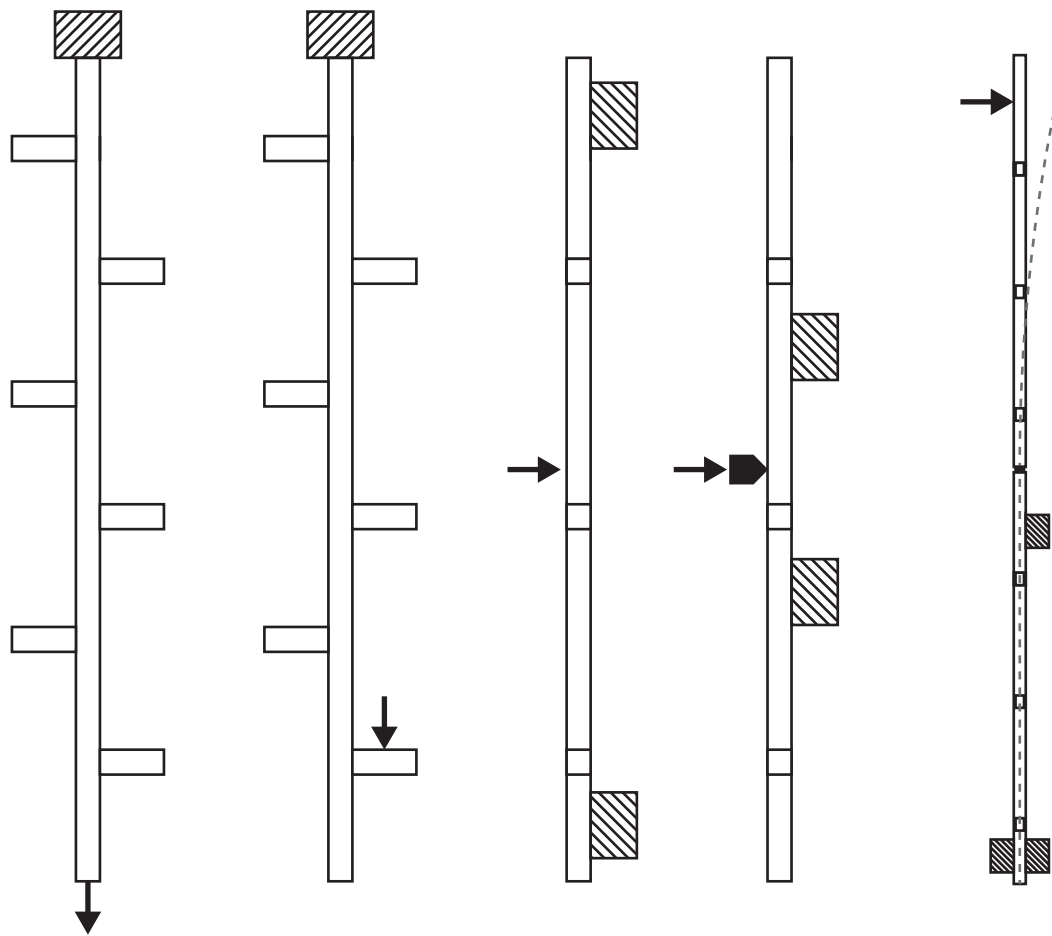

Test	UPL	Carbon Ladder	Tactical Ladder	Units
Tension Break Load	3660	2970	2170	kg
Step Break Load	990	550	775	kg
Flex	15	10	10	mm @ ~125 Kg
Crushing	490	350	600+	Kg @ R=3mm / d=15mm
Bending	147	146,5	120	mm @ 20 Kg (incl. Joint)
Weight	1682	2418	2310	g
Effective Length	1700	1700	1553	mm
Weight / m	0,989	1,422	1,487	kg/m
Stackability	Yes	No	No	
Salt water resistance	Yes	Yes	Partially	
Diving suitability	Yes	Yes	No	
Typical Reach	12	11	10	m

TACTICAL LADDER

The REBS Tactical ladder is a rigid section aluminum ladder with great strength and versatility. Fixed ladders are in many cases a more effective alternative than flexible ladders. The Tactical ladder can be use in maritime operations and is also well suited for entering buildings or ledges in urban environments.

The REBS® Tactical Ladder is a lightweight rigid section ladder that is well suited for both urban and marine boarding and entering.

To achieve up to 10 m length, the operators can connect 5 Tactical Ladder sections and a 1,5 m wire ladder for a superior reach with a well optimized configuration.

The Tactical Ladder is very robust and is made from forged and anodized aluminum. The rungs are fastened with dual rivets.

The ladder element, the flexi element, the hook and all surrounding gear is connected with quick release pins.

In marine environments, combining the Tactical Ladder with a wire ladder will provide the same advantages by extending the effective length of the total system. The wire ladder will also provide additional reach as well as increased operational safety in a RIB / boarding craft by reducing the likelihood of the boat jarring the ladder from its hold while riding alongside the target ship.

The Tactical Ladder is particularly well suited for urban operations. With our base stabilizer and wall support it is great for situations where hook attachment is not possible.

Specifications	
MBL	1000 kg / 2204 lbs
Typical reach	10 m / 33 ft
Section weight	2,3 kg / 5 lbs
Available colors	Black, Sand
Section length	1,6 m / 5.25 ft



TACTICAL LADDER - SYSTEM OVERVIEW

REBS Ladder 1,6 m section
BE004511



Flexielement
BE004636



REBS Wire Ladder 1,5 m
BE002460



Single Step
BE004515



REBS Hook Tactical 7" / 10"
BE004512 / BE005746



REBS Tactical Hook Handle*
BE000377



REBS Hook Dual 6,8" Tactical
BE004514



Tactical Base Stabilizer
BE006526



Wall & Corner Support
BE006527



Bag
BE003342

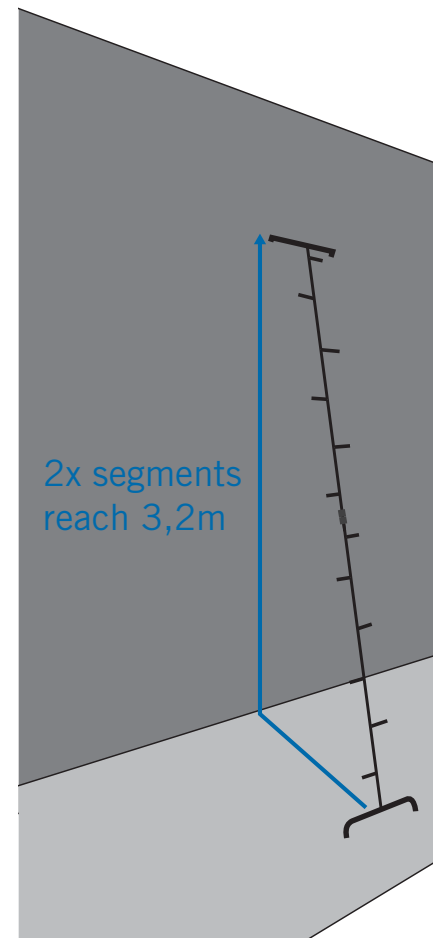

Tactical Ladder Packages				
Part Name	Part no.	7" Hook BE006870	10" Hook BE000151	Dual Hook BE006872
REBS Ladder Section 1,6 m	BE004511	4	4	4
REBS Hook 7" Tactical	BE004512	1	-	-
REBS Hook 10" Tactical	BE005746	-	1	-
REBS Hook Dual 6,8" Tactical	BE004514	-	-	1
REBS Tactical Hook Handle	BE000377	1	1	-
Single Step	BE004515	1	1	1
Flexielement	BE004636	1	1	1
Bag	BE003342	1	1	1
Wire Ladder 1,5 m	BE002460	1	1	1

ULTRALIGHT POLE LADDER (UPL)

The REBS® Ultralight Pole Ladder (UPL) is our latest single stile ladder. It is lighter, easier to stack and carry, and stronger. A light weight rigid section ladder that is excellent for both urban and marine boarding and entering.

The UPL is delivered in 1,7 m sections. Depending on the hook used, the system can reach up to 12 m (39 ft) The total length is achieved by connecting (top to bottom): hook, top adapter, five sections of 1,7 m each, an optional single step and a 1,5 m wire ladder. Each section is molded using the latest in carbon fiber molding technology. A coat of durable non slip paint has been applied to the steps. This layer is easy to repaint when necessary, increasing lifespan of the ladders.

The quick connectors make it safe, fast and easy to assemble the sections together. The modular design makes it easy to assemble the required amount of sections to make up the right length for the task at hand.

The ladder has rubber tipped standoffs that provide good space for hands and feet which increase climbing comfort and efficiency.

By attaching a flexible wire ladder at the bottom of the ladder sections, an additional 1,5 m of reach is gained. In addition to increasing the total length, the wire ladder also keeps the lowest step closer to the ground.

In marine environments the wire ladder will provide additional reach as well as increased operational safety. The RIB / boarding craft will not be able to knock the ladder off its hold when it is riding on the waves.

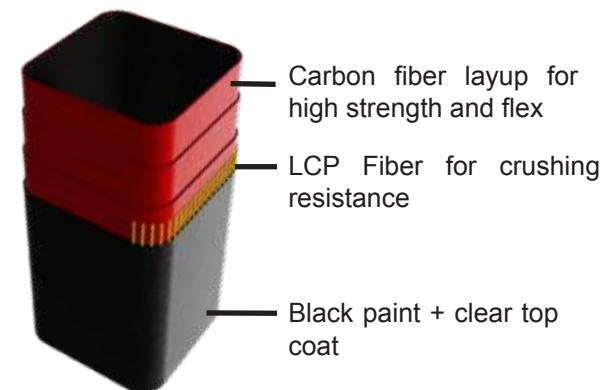

Specifications	
MBL*	3300 kg / 2645 lbs
Typical reach	12 m / 39,4 ft
Section weight	1,7 kg / 3 lbs
Section length	1,7 m / 5.6 ft

*Depending on configuration, hook type, and use case



UPL - SYSTEM OVERVIEW

REBS Ultralight Pole Ladder
BE008007



REBS Hook Dual 6,8" Tactical
BE004514



Top Adapter
BE008148



REBS Wire Ladder 1,5 m
BE002460



UPL Transport Bag
BE000295

May be used on the back of operator or lifted and carried by two operators.



REBS Hook Tactical 7" / 10"
BE004512 / BE005746



REBS Tactical Hook Handle*
BE000377



UPL Packages				
Part Name	Part no.	7" Hook BE000148	10" Hook BE000149	Dual Hook BE000150
Ultralight Pole Ladder	BE008007	5	5	5
REBS Hook 7" Tactical	BE004512	1	-	-
REBS Hook 10" Tactical	BE005746	-	1	-
REBS Tactical Hook Handle*	BE000377	1	1	-
REBS Hook Dual 6,8" Tactical	BE004514	-	-	1
Single step	BE000034	1	1	1
Top Adapter	BE008148	1	1	1
REBS Wire Ladder 1,5 m	BE002460	1	1	1
Transport bag	BE000295	1	1	1

NEW!

UPL JUNIOR

REBS UPL Junior (BE000490) is a half section of the Ultralight Pole Ladder or a system by itself. The innovative, lightweight, strong and smooth design is derived from the same advanced molding techniques also used to fabricate modern bicycle frames and components. As a result of the state-of-the-art fabrication process, the ladder design optimizes the carbon fiber properties into a very strong monocoque frame. The Carbon Multi Ladder system packs into a low-volume package that is easily carried on a backpack or with the custom CML Backpack. The Carbon Multi Ladder can be used in multiple configurations.



Specifications	
MBL*	1200 kg / 2645 lbs
Typical reach	12 m / 39,4 ft
Section weight	1,7 kg / 3 lbs
Section length	0,9 m / 5.6 ft

*Depending on configuration, hook type, and use case

REBS®

CARBON MULTI LADDER (CML)

The Carbon Multi Ladder is a multi function ladder system comprised of carbon fiber ladder sections. The innovative, lightweight, strong and smooth design is derived from the same advanced molding techniques also used to fabricate modern bicycle frames and components. As a result of the state-of-the-art fabrication process, the ladder design optimizes the carbon fiber properties into a very strong monocoque frame. The Carbon Multi Ladder system packs into a low-volume package that is easily carried on a backpack or with the custom CML Backpack. The Carbon Multi Ladder can be used in multiple configurations.

The Carbon Multi Ladder system is a versatile system with multiple functions, its main usage modes are:

1. Suspended by hook(s)
2. Leaning against wall
3. Stretcher
4. Bridge

The ladder segments and its components are rapidly and easily assembled with stainless steel quick release pins.

Shown below is a detailed view illustrating the innovative design made possible by the molding process. The circular indentations have corresponding bosses which align and lock the ladder segments when stacked.

The Carbon Multi Ladder has the same interface as the Tactical Ladder which gives full compatibility with the Tactical Hook and flexi element.

The top adapter is made from high performance Aluminum alloys and enables the ladder to be used with both one or two hooks.



This picture shows 3x CML Sections plus all equipment necessary for all 4 main usage modes packed with the CML Backpack.

Specifications	
MBL (Suspended by Hook)	1000 kg / 2204 lbs
Section weight	1,85 kg / 3.7 lbs
Section length	0,9 m / 2.95 ft



REBS®

CML USE

The Carbon Multi Ladder system stacks into a compact and stable package for transportation and storage.

URBAN & MARITIME USAGE

Depending on desired angle, stack up to five sections for a total ladder length of 4,5 m and use them as a leaning rung ladder to scale a wall. The Carbon Multi Ladder is a very efficient tool for urban operation.

Mount the top adapter for use in maritime operations. Stack three sections, the top adapter with hooks and flexi elements, and a wide wire ladder for an efficient maritime boarding tool. The top adapter accommodates either single or dual hook setup. The hanging ladder configuration is also great for certain urban operations, and can also be equipped with our MaxGrip hook. The MaxGrip hook is developed especially for urban use, and is particularly suitable for compound structures.

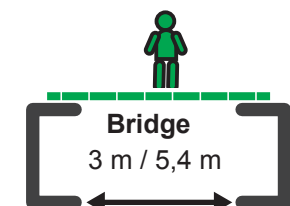
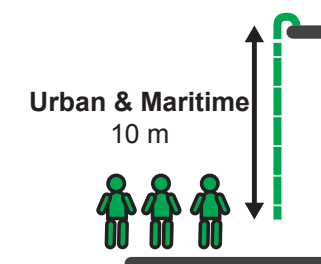
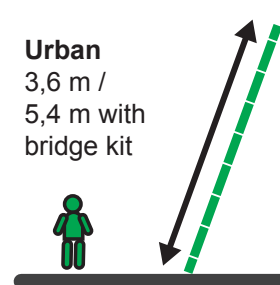
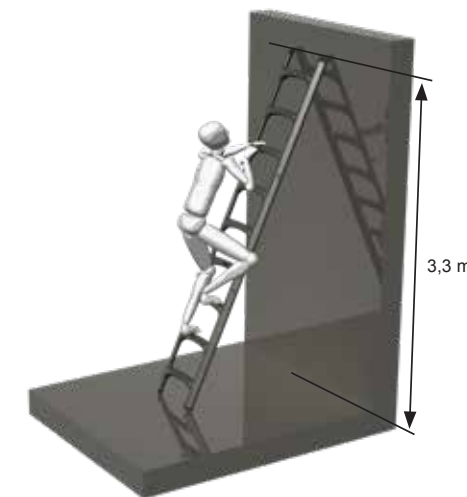
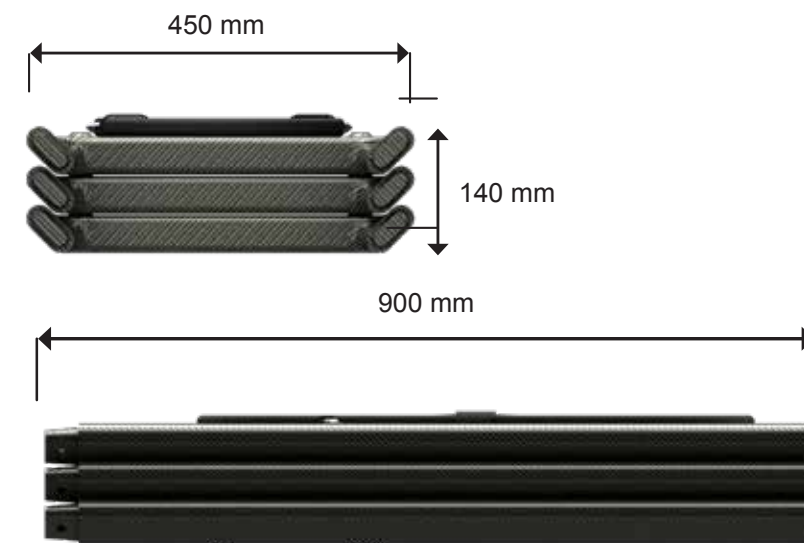

CML USE

SUSPENDED FROM HOOK(S)

The Carbon Multi Ladder can reach up to 10 m high ledges. In a hanging position the minimum breaking load (MBL) is 1000 kg.



SINGLE / DOUBLE HOOKS

The Carbon Multi Ladder developed for use with our Tactical Hooks, and used with either single or dual hook setup. Our new Tactical Hooks (BE000298+BE000299) is developed to fit the Carbon Multi Ladder with a twisted angle that fits our Flexielement as well.



BE000298+BE000299 REBS 10" CML Right /Left with the flexielements.



Single Hook with Top Adapter.

CML USE

SCAFFOLDING LADDER

Use the angle connectors to connect the sections together at angle. Also use the rubber feet in the end of the CML, to protect the carbon fiber surfaces. The specified MBL capacities will maintain, including leaning, hanging and bridge.



BE007566 Rubber Foot



BE007569 CML Angle Connector Kit



PROTECTIVE RUBBER ENDS

The rubber feet and tops both protect the ladder from hard abrasive surfaces as well as provide friction against slippery surfaces and act as shock absorbers. A wide wire ladder has been developed to give the Carbon Multi Ladder extra flexibility and ease of use.

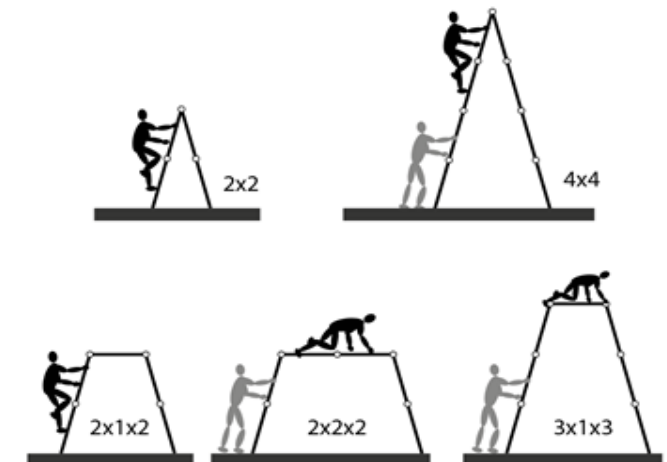

REBS®

CML - STRETCHER

HANDLES

Connect two sections and four handles to make a stretcher. With the handles the stretcher is ergonomic and easy to carry. The handles can be quickly removed to fit into helicopters and other tight spaces. The handles provide a good grip while also keeping the stretcher lifted off the ground.



EMERGENCY EVACUATIONS

The stretcher handles keep the stretcher off the ground and protect the hands of the operators carrying it. The hand protectors double as runners which makes possible single handed emergency evacuations by pulling the stretcher as a sled. The stretcher bed has an integrated lifting harness which enables vertical lifts of patient in stretcher, e.g. for helicopter evacuation.



REBS®

The CML Backpack fits up to 6 x ladder sections and all needed equipment.



Bridge Line Kit

BRIDGE

Stack three elements to make a bridge. The bridge has been tested to a MBL of 200 kg / 440 lbs at the center when laid across a 3 m / 9.8 ft gap. A bridge kit which allows users to cross gaps of up to 5,4 m / 17.7 ft (6 sections) as shown on the picture below is also available for advanced users.



CML SYSTEM OVERVIEW

REBS CML Section
BE007564



Top Adapter with Pigg Release
BE007630



REBS Hook Tactical 7" / 10"
BE004512 / BE005746



REBS Hook 10" CML Right / Left
BE000298 / BE000299



Wall Stand-off
BE007599



REBS Wire Ladder Wide 1,5 m
BE002481



Rubber Top
BE007565



Flexielement
BE004636



Rubber Foot
BE007566



REBS Hook Dual 6,8" Tactical
BE004514



Quick Release Pin ø12 x 35 mm
BE007689



Bridge Line Kit
BE007786



Stretcher Handles Tops Kit
BE000253

Female Left
BE000241

Female Right
BE000242



Stretcher Handles Feet Kit
BE000252

Male Left
BE000239

Male Right
BE000240



Angle Connector Kit (R+L)
BE007569

Left Side
BE007691

Right Side
BE007692



CML Top Adapter with Pigg Release, Step Fork and Rope Clamp
BE007567



CML Step Fork
BE007596



CML Rope Clamp
BE007597



Backpack
BE007687



CML PACKAGES TABLE

FUNCTION	Part. no.	Sections	Back Pack	Rubber Top	Rubber Foot	Top Adapter w/ Pigg	Top Adapter w/ Pigg & Bridge Kit	Bridge Line Kit	Flexi element	Tactical Hook	MaxGrip Hook	Wall Stand-off	Stretcher Handles Tops Kit	Stretcher Handles Feet Kit	Wire Ladder Wide	Angle Connector Kit
Stretcher Kit	BE007564	2	1	-	-	-	BE007567	-	-	-	BE001720	BE007599	BE000253	BE000252	BE002481	BE007569
Hanging	1 - 8	1 - 8	Optional	-	-	1	-	-	1 - 2	1 - 2	Optional (Urban)	1 - 4	-	-	Optional (Maritime)	-
Leaning 4,5 m max.	1 - 5	1 - 5	Optional	2	2	-	-	-	-	-	-	-	-	-	-	-
Leaning 7,2 m max.	8	8	Optional	2	2	-	1	1	-	-	-	-	-	-	-	-
Bridge 3 m max.	3	3	Optional	-	-	-	-	-	-	-	-	-	1	1	-	-
Bridge 5,4 m max.	6	6	Optional	-	-	-	1	1	-	-	-	-	1	1	-	-
Scaffolding Ladder	2 - 8	2 - 8	Optional	2	2	-	-	-	-	-	-	-	-	-	-	1 - 2

LADCARB CARBON ATV BRIDGE

LADCARB CARBON ATV/QUAD BRIDGE is a new revolutionary product allowing light quad bikes up to 650 kg to cross ditches or brooks up to 3 meters and to overcome lower walls. In addition to this, the product can be used as a loading ramp, as a single-track footbridge up to 6.8 m and as a multi-function assault ladder meeting all requirements of the EN 1147 Standard.

The bridge made of extremely strong, light and durable carbon composite tubes is designed for maximum portability and versatility. The whole set can be transported on the ATV rack (either on one rack as a whole or it can be divided on front and rear rack) and deployed by one man in less than 3 minutes. The set consists of six 4-rung sections which can be easily connected using ball-locking pins. Unique flexible connectors allow placing of track on uneven terrain. Anti-slip top and bottom endings not only protect the ends of stiles against damage but also allow using of the product as a leaning ladder.

Thanks to endurance of the structure, single or connected sections can also replace indispensable snow/sand recovery tracks.



Specifications	
Maximum length	3,5 m / 11,5 ft
Section length	1,22 m / 4,0 ft
Total weight (1,0 m / 1,5 m)	26 kg / 57.33 lbs
MBL ATV Bridge(2 tracks/3.1m)	1300 kg/ 2,860 lbs

ATLAS TACTICAL LADDER SYSTEM ATL

The ATL is the foundation of an ultralight Litter/Ladder/Bridge system designed for operators conducting austere special operations missions. Built on a core Atlas Devices ladder technology backbone, the ATL system combines the packable, height-conformable strength and tailor-ability of a ladder and bridge with the speed, efficiency, and security of a vertical/horizontal hoist-able patient litter. The integrated handle designs enable effective patient manipulation and longer duration carries which provide a multi-mission tool that is useful through primary and contingency phases of operations. Two ATL ladders can also be connected too-free into a extended 15 ft ladder by using the ATL-JOIN kit.



Bridge



Ladder



Litter



Hoist

CAPABILITIES AND SPECIFICATIONS

- Deployment time: <5 seconds
- Secondary positive joint locks can automatically engage on deployment
- Joints manually lockable for noise control
- Stow time: <10 seconds
- Tool free joining of up to 2 full ATL segments to yield 4,6 m / 15 ft ladder
- Compliant with relevant portions of NFPA 1931015, ANSI-ASCA14.2-2007

RECOMMENDED MISSION PROFILES

- Direct Action
- Personnel Recovery
- Asset Recovery
- Confined Space/ Structural Collapse
- CASEVAC/TACEVAC
- Urban Ops
- Maritime Ops
- Jump / MFF Ops
- Crevasse

Length	2,1 m	7 ft
Stowed envelope	410 x 480 x 230 mm	16" x 19" x 9"
Total weight	4,5 kg	10 lbs
Capacity (all configurations)	181 kg	400 lbs

KITS

RACC PATIENT PACKAGING KIT

Load rated vertical/horizontal hoisting patient packaging system including hoist bridle, patient straps, and retention/stowage covers. Originally co-developed with Roco Rescue.

MODULAR SYSTEM INTEGRATED GEAR (MSIG) PACK

An ultralight anodized aluminum MOLLE-style semi-flexible panel backpack that allows vertical and horizontal mounting options integrated into the ATL with the addition of the speed clip accessory.

ATL PATIENT PACKAGING

RACC PATIENT PACKAGING KIT

RACC (Roco-Atlas Casualty Carrier)

Load rated vertical/horizontal hoisting patient packaging system including hoist bridle, patient straps, and retention/stowage covers. Originally co-developed with Roco Rescue.

CAPABILITIES AND SPECIFICATIONS

- Components: Tubular Webbing, Patient Packaging w/ Cobra Buckles and Tactile Adjusters, Vert/Horiz Hoisting Bridle,
- In-Rail Stowage Covers, Patient Comfort Straps
- Fits within HH-60 airframe
- Rigid ATL Frame Protects Patient
- RACC Kit Weight: <3 lbs / 1.4 kg
- Tubular harness-style patient packaging straps
- In-rail stowage covers with elastic strap retention
- Patient comfort straps suspend patient over structure and secure structure when not in use
- Structure and hoist bridle system compliant with NFPA 1983-12
- Vertical and horizontal hoisting



MODULAR SYSTEM INTEGRATED GEAR (MSIG) PACK

An ultralight anodized aluminum MOLLE-style semi-flexible panel backpack that allows vertical and horizontal mounting options integrated into the ATL with the addition of the speed clip accessory.

CAPABILITIES AND SPECIFICATIONS

- Weight: 4.2 lbs / 1.9 kg
- Sizes: (20.5 and 22) x 13.5 x 1/8 in / (52 and 56) x 34 x 0.3 cm
- Flexible Anodized Aluminum Panel Frame
- Variable Suspension Load Carriage Options
- Vertical / Horizontal MOLLE Compatible frame pattern



SPEED CLIPS

Lightweight rigid pack attachment system for rapid don/doff of ATL systems from MSIG pack. Modular rung positioning enables use for mounting MSIG Sled Dog pack onto ATL to instantly create litter backplate and patient attachment method.



ATL CONFIGURATIONS

USE CONFIGURATION: HOISTING

(Requires AK-RACC accessory kit)

Litter mode easily converts between horizontal and vertical hoist modes.



CAPABILITIES AND SPECIFICATIONS

- Hoist bridles rated to 5,000 lbf / 23 kN
- Accommodates patients from 4-7 ft / 1.2 – 2.1 m
- Litter load rating suspended from bridles (average body weight distributed across rungs): >2,500 lbs / 1,134 kg
- Redundant attachment system links to four rungs each side
- Convert from vertical to horizontal configuration in <5 seconds
- Integrated ergonomic carry handles for patient carry and manipulation protect attendant's fingers
- Rigid frame protects patient and is rated for vertical pivot

USE CONFIGURATION: HIGH POINT

(Requires AK-RACC accessory kit)

The ATL with hoist bridles can be set up to provide a structural A-frame for use as a high point or redirect for high angle operations (ex. confined space, roof edge transition).

CAPABILITIES AND SPECIFICATIONS

- 400 lbs / 180 kg Load rating in all configurations
- Adjustable Bridle Footprint
- Variable High Directional Heights
- Single Point load rated
- Load Share Anchoring Capable



ATL CONFIGURATIONS & ACCESSORIES

USE CONFIGURATION: EXTENDED LADDER

(Requires 2x ATL units and 1 ATL-JOIN kit)

With a pair of extra outer rails from the ATL-JOIN kit, two complete ATL units can be joined tool-free to create a double length 15 ft ladder.

CAPABILITIES AND SPECIFICATIONS

(1 pair of ATL outer joining sections with tool less connection)

- Total Length: 15 ft (176 in) / 4.6 m (447 cm) rung to rung
- Load capacity: 350 lbs / 159 kg as ladder at 75 degrees (Safety factor >2)
- Stowed dimensions: 19 x 16 x 18 in / 48 x 41 x 46 cm
- Deployment: <10 sec
- Partial deployment allows on-the-fly tailored height
- Tool-free assembly and separation of individual ATL units
- Folding and stowing method identical to single ATL unit

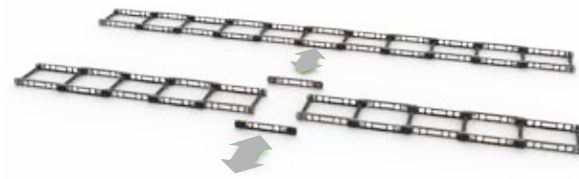

MULTI - HANDLE HOOK

- Extends carry handles for easier load carrying.
- Can create tabletop to hold patient in inclined or declined position, or hold level above ground to reduce ground contact conduction heat loss.
- In hook mode can extend the reach of an ATL by hooking over wall or rail like a pool ladder.



Multi - handle - lock

CAPABILITIES AND SPECIFICATIONS

- Weight: < 0,7 kg / 1,5 lbs (pair)
- Quickly change configurations in < 5 sec
- Stow along with ATL unit with negligible increase to stowed volume
- Ergonomic grip handle protects attendant's fingers
- Configurable carbide tipped skid/grip feature
- Rotational adjustment locking joint
- Collapsible stow position
- Tool-free rapid on/off to ATL

SKID PUCK

Configurable end caps for stable positioning or smooth draggable wear surface.

CAPABILITIES AND SPECIFICATIONS

- Weight: < 0,45 kg / 1 lbs (pair)
- Tool-free rapid on/off to ATL
- High impact plastic construction
- Carbide spikes grip at all ladder angles and catch on edge for uneven bridging
- Replaceable carbide spikes
- Negligible impact on ATL stow volume



Skid puck

LAL-14 / LAL-18

The LAL-14 / LAL-18 is a minimalist, portable, telescoping ladder. It is strong, light, intuitive to use, and quick to deploy and stow. It can be easily transported by a single user, and integrated into a backpack or other gear. The 14 foot ladder consists of 11 telescoping carbon fiber sections. The 18 foot ladder consists of 14 telescoping carbon fiber sections.

When extended, the sections are secured via two locking pins beneath each rung. The rung sections are modular, and the ladder can be utilized in any length to suit specific mission or task requirements. It can be fully extended or collapsed in under 20 seconds, without tools.



The ladder is constructed entirely of carbon fiber composite, engineered to minimize weight and maximize strength in high-stress areas.

Aggressive CNC machined aluminum feet provide maximum traction on a variety of surfaces. The exterior is dark, non-reflective, and is available with a durable protective coating for abusive environments.



Partial deploy ladder

Stowed with Backpack Straps

Specifications		
Part no.	BE000221	Pilot LAL-18
Extended height	18 ft	5,48 m
Collapsed height	28,25 in	71 cm
Width	17,75 in	45 cm
Thickness	3,75 in	9,5 cm
Weight	18,0 lbs	8,2 kg
Capacity	350 lbs at 75°	

REBS®

WIRE LADDERS

The new design of the wire ladders has the highest strength to weight ratio of any wire ladder in the world. The wire ladders have been developed with input from professional users and have high-end features for superior performance in tenuous situations. All ladders are delivered ready to use. The rungs are diamond knurled and provide a durable high friction grip surface.

Wire ladders are often used in combination with telescopic poles. The ladders are strong and rugged, but also compact in size, exceptionally light weight, and pack compactly and easily.

Our wire ladders are delivered completely prepared for immediate use. Every ladder is fitted with thimbles, proper connectors and checked and approved before they are put in stock for fast delivery.

Wire ladders are kept in stock in the standard lengths: 1,5 m, 5 m, 10 m, 15 m and 20 m (5, 16,5, 23, 33, 49 and 65,5 ft), but custom lengths can be delivered upon request.

The ladder has a market-leading strength to weight ratio, and minimum breaking load (MBL) of 1,200 kg.

The wire ladder is made with the highest quality components and materials. The Ø3 mm (1/8 in) wire rope and thimble are made from 316L stainless steel and the rungs are black anodized 6082 T6 aluminum.

The rungs are fastened to the wire rope with an innovative and very strong mechanical bond. The bond has been tested to 470 kg on a single side without breaking.



Available lengths		
Length	Part no.	Weight
1,5 (1,30) m / 4,9 ft	BE002460	0,33 kg / 0.73 lbs
5 (5,20) m / 16,4 ft	BE002420	0,92 kg / 2 lbs
7 m / 23 ft	BE002538	1,20 kg / 2.6 lbs
10 m / 32,8 ft	BE002461	1,75 kg / 3.8 lbs
15 (14,80) m / 49,2 ft	BE002462	2,43 kg / 5.35 lbs
20 (19,90) m / 65,6 ft	BE002463	3,26 kg / 7.2 lbs

Specifications	
Available lengths	1,5 - 5 - 7 - 10 - 15 - 20 m
Wire MFBL	1200 kg / 2645 lbs eye-eye
Step MFBL	200 kg / 441 lbs (24 mm / 1" center load)
Step width	137 mm / 5.4"

REBS®

WIRE LADDERS

SYSTEM OVERVIEW



Wire rope end with thimble and carabiner hook..



STRONG AND WELL BUILT

The ladder rungs are slightly arched to achieve high strength and all edges are smooth and rounded. The result is a very strong construction and superior climbing comfort.

WIRE LADDER PROTECTOR

BE000461 is a protection sleeve for the wire ladder. Especially useful when using the ladder over a sharp edge of a ship.

All sleeves open



All sleeves closed



WIRE LADDER DETAIL DRAWING

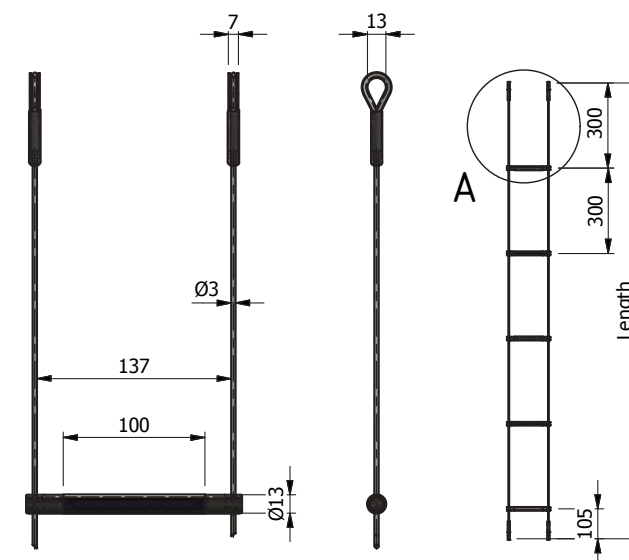

All wire ladders are delivered in a black nylon bag as standard.

REBS®

FIFI LADDER HOOK

Upgraded!

The FIFI Ladder Hook (BE000477) is a compact safety hook made for use with our wire ladders.

The wide arch on our FIFI hook will spread out the weight of the operator across a bigger portion of the step. This greatly reduces the chance of breaking the steps, compared to an ordinary FIFI hook.

The FIFI ladder hook connects to your harness and is preferably used with retrieval lines near the chest area so it can be located quickly and hung onto to a ladder step. The FIFI hook supports the load of the operator and is useful for resting or situations where two free hands are needed. When used with retrieval lines, the user can simply resume climbing and the retrieval lines will pull the hook off the step and return it to its position near the users chest.

The FIFI ladder hook is precision machined from a single piece of high performance aluminium alloy. It has a MBL of 400 kg but the limiting factor will be the step MBL which is 270 kg when the FIFI ladder hook is placed on the center of the step.

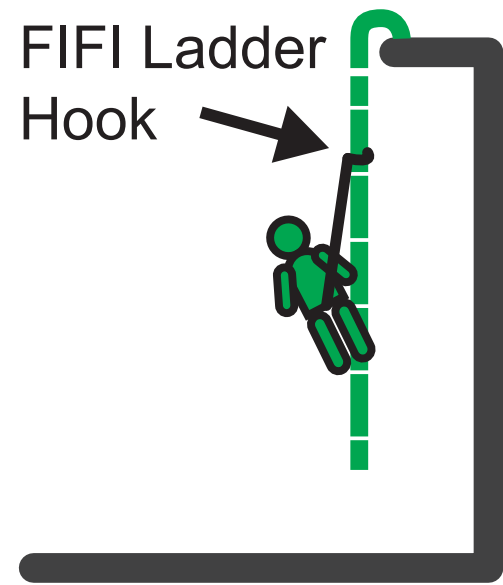

DISTANCE WHEEL

BE000085 Distance Wheel can be added to any of our wire ladders. The Distance wheel can reduce pinching and make climbing easier and safer.



REBS®

WIRE CUTTER

Upgraded!

A major increase in operational safety can be achieved, by adding the Wire Cutter to your tool kit. (BE000482)

The Wire Cutter is a pole mounted tool that will allow you cut straight through steel wire ropes up to 5 mm diameter. This capability can be crucial in case where a steel rope unintentionally snags or tangles onto gear, or personnel. The wire cutter standard kit includes all operating parts and a telescopic pole.

The illustration below shows a typical scenario for using a wire cutter. An operator could get stuck in a dangerous position hanging from a wire ladder. This is especially critical if the operator ends up in or under water.

Without long reaching tools there is also a high risk of pinching the operator between the ship side and the RIB. In this situation the Wire Cutter is a great tool for cutting the wires quickly and from a distance, and thereby freeing the operator from this position.

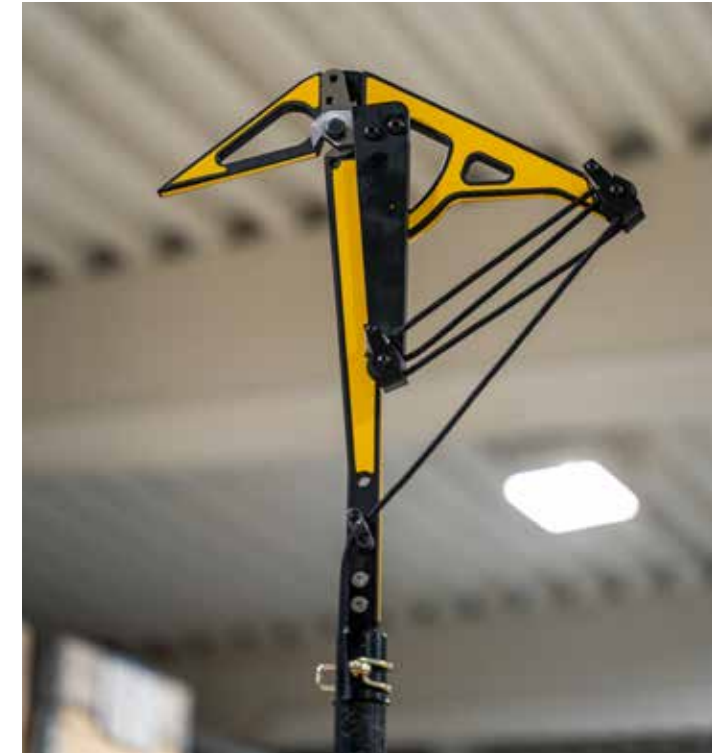

Specifications

Capacity	Ø5 mm steel rope
Typical reach	3-4 m



REBS®

LADDER REEL

The Ladder Reel is used to efficiently operate wire ladders up to 15 m (50 ft) long. Its functional, strong, flexible and lightweight design makes it perfect for fast operation of wire ladders, but is also beneficial for transportation and storage. It features a carabiner hook for securing the ladder to the reel and a snap hook for holding the ladder in place when it is rolled on. A collapsible handle on each side enables fast and precise handling.

OPERATION

Hook the ladder on to the center of the empty Ladder Reel with the carabiner hook. Roll the wire ladder onto the reel. When the ladder is rolled completely into place, the snap hook is used to secure the ladder in the wound position to ensure it cannot unwind. Collapsible handles unfold from each side, each with a nylon strap on its end. Pull the strap to extend the handle, and twist to lock.

CONSTRUCTION

The Ladder reel is constructed from rubber castings around a spring steel insert. This ensures high performance, and flexibility with high strength, and the rubber sheath prevents damage and abrasion to surrounding equipment.



The handles are fast and easily collapsed into the ladder reel for fast and easy transportation and handling.

The handles enables fast spooling of the wire ladder on and off the ladder reel.

New plates: The side plates of the Ladder Reel is in a new version.

Specifications	
Capacity	15 m / 49 ft
Weight	3 kg / 6.6 lbs
Dimensions	Ø310 x 175 mm / Ø12.2 x 6.9 in
Part no.	BE005538

REBS®

WIDE WIRE LADDER

The wide wire ladder is a good alternative when you want more room for your hands and feet. It is strong, light and easy to climb. The wide wire ladder is also optimized for use with the CML and Pool Ladder.

The wide wire ladder is suitable for both urban and marine environments.

The wide wire ladder was made to enable a more comfortable climbing movement. Each step provides a large and flat anti slip surface. The ladder is easy to connect to any rigid ladder and light and easy to carry around.

The steps are made of high quality aluminium alloy. The steps are made with an integrated anti slip profile. The wire is made from 316L stainless steel.

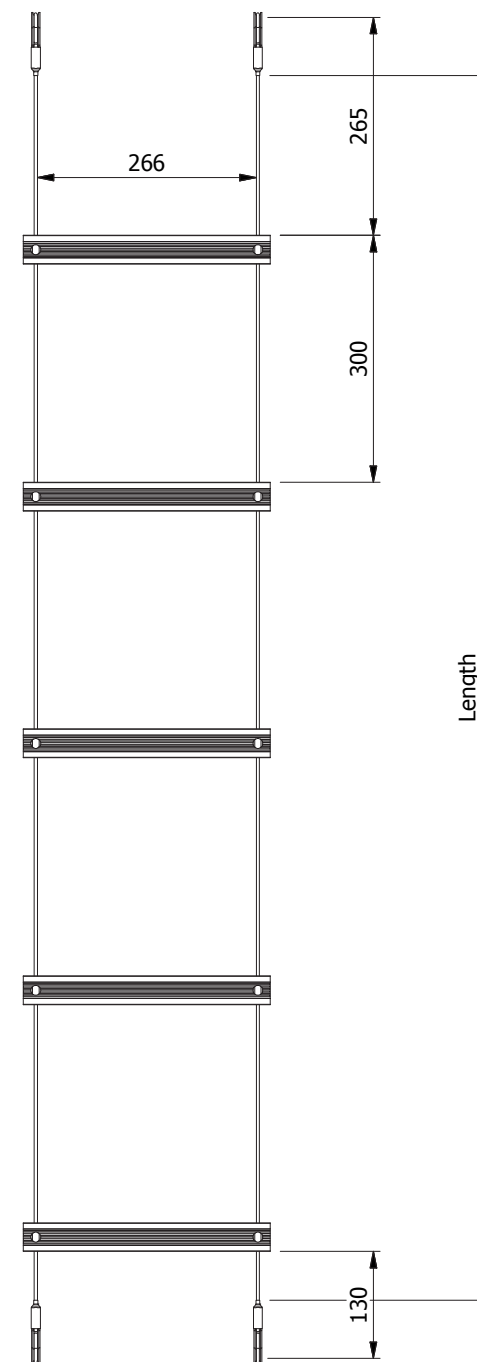

**WIRE LADDER COMPARISON:
WIDE WIRE LADDER & WIRE LADDER**

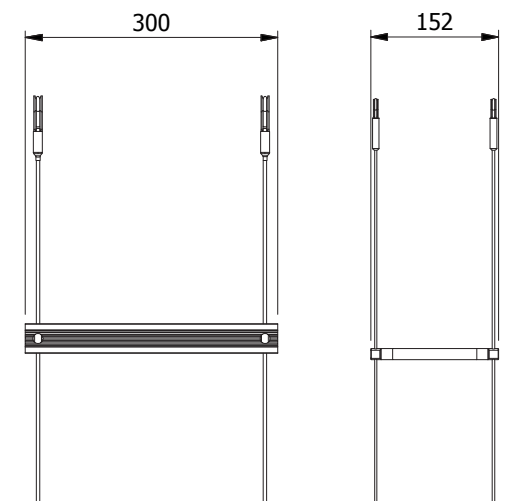

Length	Weight	MBL Steps	MBL Wire	Part no.
1,5 m / 4,9 ft	1,4 kg / 3,1 lbs	1000 kg / 2204 lbs	1000 kg / 2204 lbs	BE002481
3 m / 9,8 ft	2,5 kg / 3,3 lbs	1000 kg / 2204 lbs	1000 kg / 2204 lbs	BE002482

REBS®

ROPE LADDER

A rope ladder with aluminum steps. Super compact in size and low weight. Can be fired from a launcher or used with our other poles. It is developed with input from professional users and has high end features for maximum performance.

The rope ladder is used where a ladder with the least size and weight is required. It is supplied with our launchers as a standard part of the launcher packages.

The Launcher is able to fire a hook with rope ladder 25 meters (82 ft) vertically, and the Compact Launcher is able to achieve a 16 m (53 ft) vertical placement. The rope ladder features high tensile fiber vertical lines with aluminum steps, and is extremely compact in size and low in weight. It was designed with input from professional users to optimize its performance and specifications.



The minimalistic approach of a step ensures the lowest possible weight.



The top part of the ladder has rubber protection covering the rope to protect the ladder from sharp edges.



Placing the rope ladder with a grapnel hook to the roof of a building using the REBS Launcher.



Specifications	
25 m Part no.	BE002477
16 m Part no.	BE002458
6 m Part no.	BE004206
Rope strength	900 kg / 1984 lbs eye-eye
Step strength	340 kg / 750 lbs
Step width	135 mm / 5,3 in

REBS®

WEB LADDER

The web ladder is a good alternative especially for urban operations, where low noise is important. It is strong, light weight and easy to climb.

The rigid steps are constructed using 3/8 inch solid "carbon fiber" rods which are inserted into a specially woven, multi-layered specially designed rope sheath with a slip resistant, textured surface.

The main advantages of web ladders are high strength and abrasion resistance, and low weight and noise.

The main bodies of the ladders are constructed of extremely lightweight Kevlar webbing to eliminate stretch while in use. The ladder is very suitable for boarding of vessels in combat situations, and can also be used to egress from urban buildings. Ladders can be linked together and are compatible with drag/grappling hooks or extension poles to gain access to unreachable areas.

The Launcher model is the lightest and most stripped down version, designed for use with our grapnel hook launchers.

The Urban model has two standoffs that helps climbing comfort. For urban use it is also noteworthy that the web ladders are very quiet in use. It is delivered ready for use with two carabiners.

The Maritime model has three sets of rubber standoffs built into ladder on top ten feet as well as extra three soft steps between the top four steps. This makes it easier to position and climb over ship sides, railings and so on. It is delivered with two carabiners.

The ladders are delivered in a black nylon bag.



Step detail: The steps are constructed using solid "carbon fiber" rods in a specially woven multi-layered rope sheath. The "rungs" are made from Kevlar webbing.



Urban Web Ladder top: Two carabiners for fastening and two standoffs on the second step

Part Name	Part no.	Length	Weight	MBL Step	MBL Webbing
REBS Web Ladder for Launcher 16 m	BE002560	16 m / 52 ft.	1,9 kg / 4.2 lbs	380 kg / 840 lbs	1400 kg / 3085 lbs
REBS Web Ladder for Launcher 25 m	BE002561	25 m / 82 ft	3,0 kg / 6.6 lbs		
REBS Web Ladder Urban 6 m	BE000050	6 m / 20 ft	1,0 kg / 2.2 lbs		
REBS Web Ladder Urban 10 m	BE000051	10 m / 33 ft.	1,4 kg / 3.1 lbs		
REBS Web Ladder Maritime 10 m	BE008200	10 m / 33 ft	1,7 kg / 3.7 lbs		
REBS Web Ladder Maritime 16 m	BE000052	16 m / 52 ft	2,4 kg / 5.3 lbs		

WEB LADDER MODELS OVERVIEW

HOOKS

Dimensions

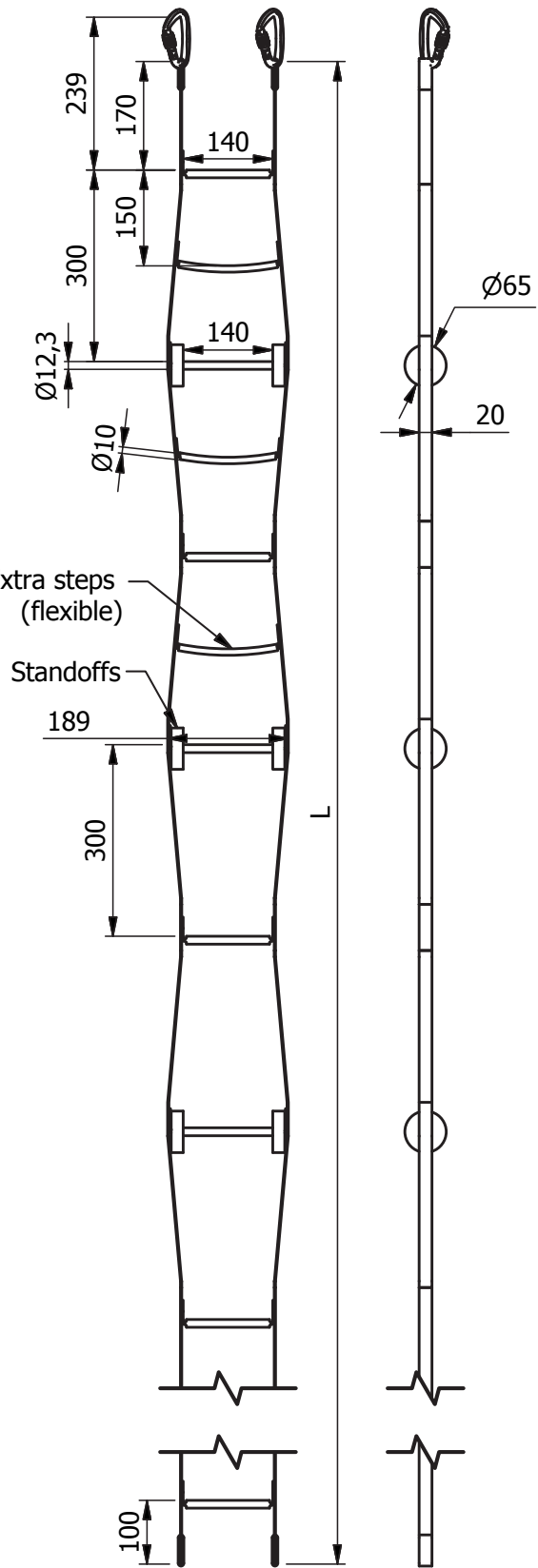

Launcher

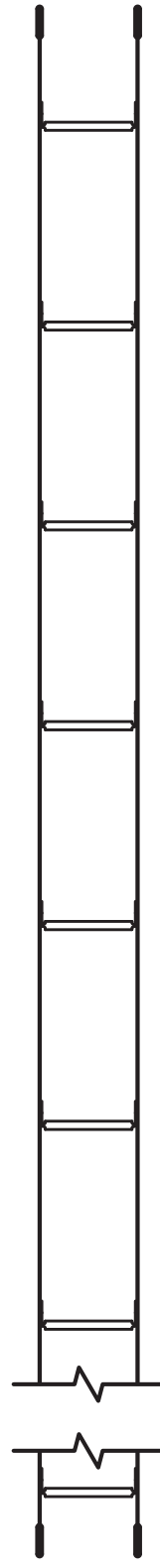

Urban

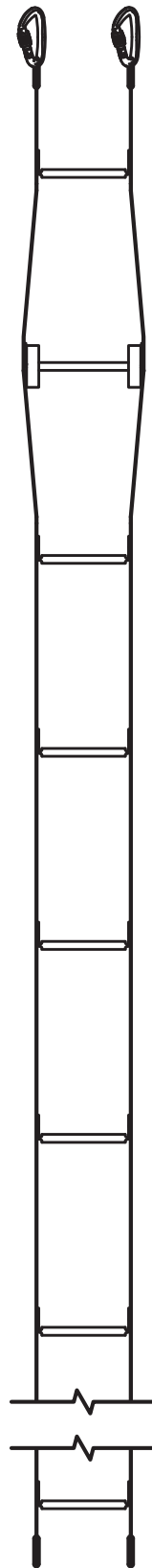

Maritime

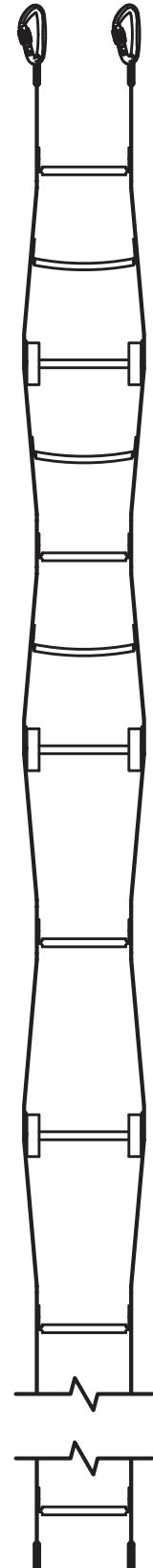

HOOKS INTRODUCTION

Hooks are available in both single and dual configurations, and are delivered in several sizes between 2,5" and 10" to accommodate a large range of different boarding operations and entering operations and fixture points.



Single Hook



Dual Hook

Some users prefer the dual hooks because of the increased stability they provide. The disadvantage of the dual hooks is that the forces from climbing in the ladder may cause the hook to "walk" or move if it is suspended on the hook tips.

The nominal dimension of the hook is equal to the size of the hook opening: a 2,5" hook will fit perfectly around a cylinder with a diameter of 2,5".



All REBS® hooks are made to be strong, light and efficient. Strength ratings are provided in two different scenarios: arc loading and tip loading.

ARC LOAD

The optimal way to fasten a hook is within the arc, as this gives the best distribution of forces through the hook, giving the best load rating.

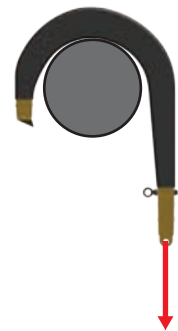

TIP LOAD

Tip loading increases the forces on the hook, lowering its rating, but can be beneficial as the hard metal tip insert digs into most surfaces for maximum grip and minimum risk of losing its hold. Note that arc loading is preferred when available. All hooks are tested prior to deliver unique serial number.

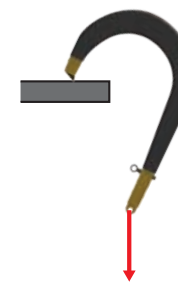

MINIMUM BREAKING LOAD (MBL)

The hooks are specified with a Minimum Break Load, which means that the hook will not fail when loads of up to the MBL are applied. Permanent deformation at loads approaching the MBL is allowed and expected.

SAFETY FACTOR

A minimum safety factor of 2 is recommended when planning and executing operations but users shall work out their own directives based on the conditions and the scenarios of the application. Unforeseen factors like sea conditions, minor falls, harmonic climbing and similar events can result in significant dynamic loading that may cause the total load to exceed the MBL rating. Please take contact for more guidance or training if necessary.

HOOK INTERFACES

REBS hooks can be supplied with several different interfaces that enable their use with each of the different placement systems including carbon poles, giraffe and windup poles, and Rolatubes. The different interfaces includes:

Pigg Release

The Pigg Release system is an adapter with a pin that connects into the top adapter of a placement tool, such as a telescopic pole. After the hook is attached to the ledge, the pin can be pulled, and the Pigg release will let go of the pole, leaving behind a clean anchor.



Rolatube

Rolatube attachments allow for easy placement and separation of the hook from the pole, similar to the pigg release.



Tactical connector

The Tactical connector consists of a conical slot which gives the system a great fit and is secured with a quick release pin.



POLE RELEASE ALTERNATIVES

The mounting bracket is suitable for various applications. Alternative pole release solutions are available to suit most boarding operations. These include the standard pigg release, the ring fastening and the locking pin release system.

PIGG RELEASE

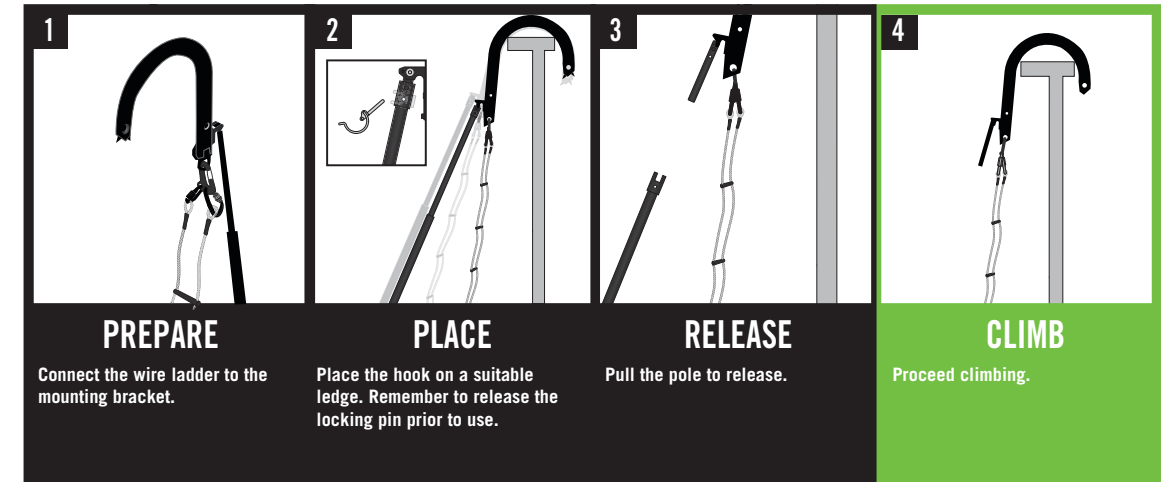

LOCKING PIN RELEASE SYSTEM

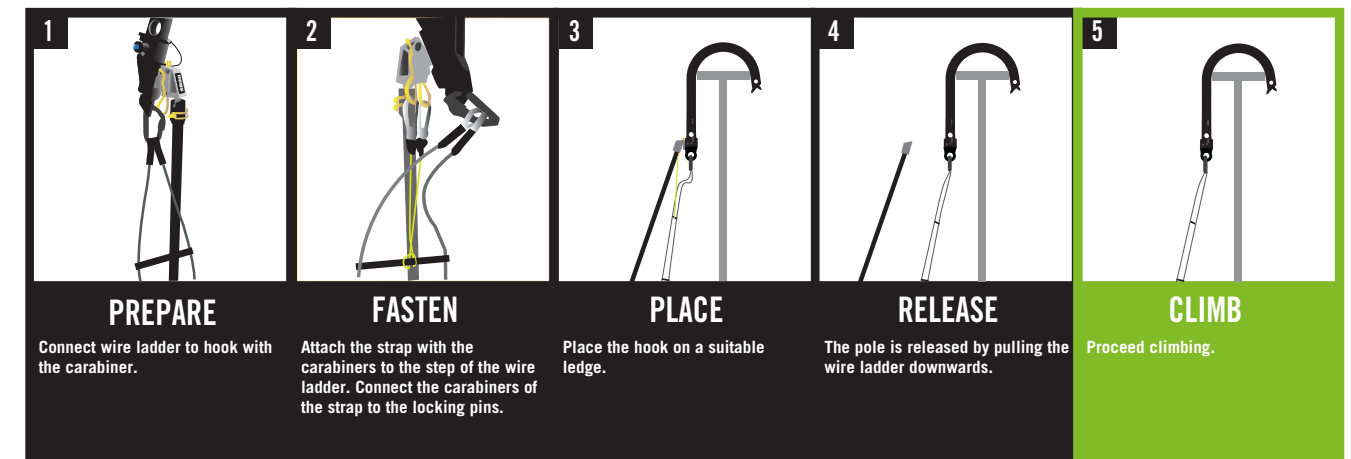

RING FASTENING (9 M AND HIGHER)

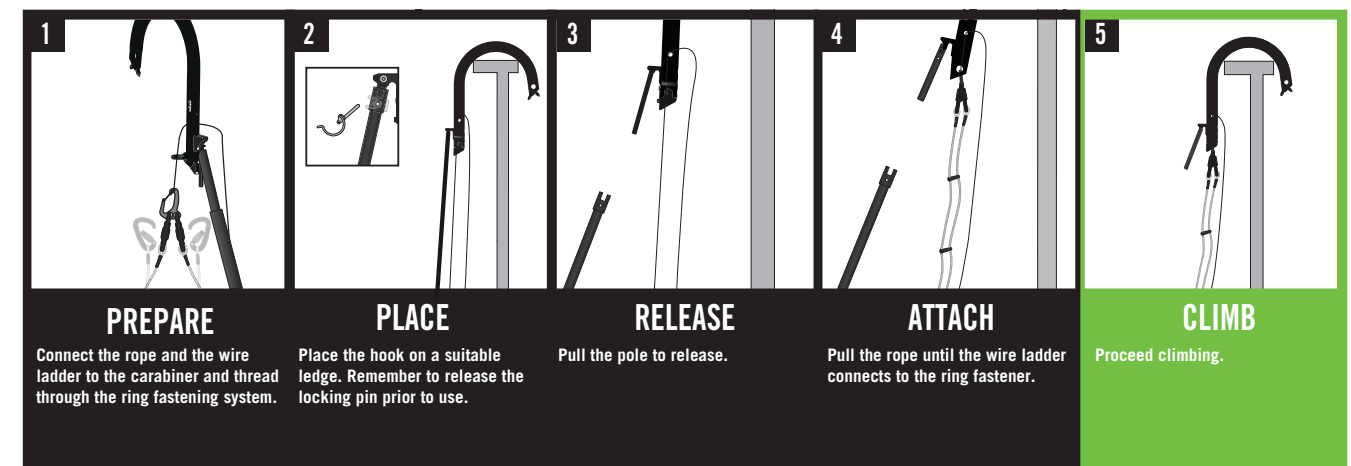





REBS Hook 2,5" Titanium with Rolatube L adapter	
MBL (Tip)	1400 kg / 3086 lbs
Weight	0,37 kg / 0,82 lbs
Part no.	BE000356
Compatible with	Rolatube



REBS Hook 5" Titanium with Rolatube L adapter	
MBL (Arc)	2000 kg / 4409 lbs
Weight	0,6 kg / 1.0 lbs
Part no.	BE000363
Compatible with	Rolatube



REBS Hook 2,5" Titanium with Pigg Release	
MBL (Tip)	1400 kg / 3086 lbs
Weight	0,38 kg / 0.84 lbs
Part no.	BE000352
Compatible with	Manual Telescopic



REBS Hook 5" Titanium with Pigg Release	
MBL (Arc)	2000 kg / 4409 lbs
Weight	0,65 kg / 1.50 lbs
Part no.	BE000332
Compatible with	Manual Telescopic Windup Telescopic



REBS Hook 7" Titanium with Pigg Release	
MBL (Arc)	2200 kg / 4941 lbs
Weight	0,84 kg / 1.85 lbs
Part no.	BE000212
Compatible with	Manual Telescopic Windup Telescopic



REBS Hook 10" Aluminium	
MBL (Tip)	1000 kg / 2204 lbs
Weight	1,3 kg / 2.86 lbs
Part no.	BE000106
Compatible with	Manual Telescopic Windup Telescopic



REBS Hook MaxGrip with Pigg Release	
MBL (Inner two spikes)	1000 kg / 2204 lbs
Weight	1,5 kg / 3.3 lbs
Part no.	BE001725
Compatible with	Telescopic Pole



REBS Hook 9,5" Carbon Fiber w/ adapter	
MBL (Tip)	1350 kg / 2976 lbs
Weight	1,1 kg / 2.4 lbs
Part no.	BE000491
Compatible with	Manual Telescopic Wind Up Giraffe Tracer



REBS Hook for Giraffe Tracer	
MBL (Tip)	1500 kg / 3306 lbs
Weight	1,7 kg / 3.7 lbs
Part no.	BE003346
Compatible with	Giraffe Tracer



REBS Hook 5" Titanium	
MBL (Arc)	1800 kg / 3968 lbs
Weight	0,75 kg / 1.6 lbs
Part no.	BE000330
Compatible with	Manual Telescopic Windup Telescopic Giraffe Tracer



REBS Hook 7" Titanium	
MBL (Arc)	1350 kg / 2976 lbs
Weight	0,83 kg / 1.82 lbs
Part no.	BE000210
Compatible with	Tactical Ladder CML Ultralight Pole Ladder



REBS Hook 13" Tactical	
MBL (Tip)	2170 kg / 2204 lbs
Weight	2,186 kg / 4,82 lbs
Part no.	BE000435
Compatible with	Skypole Wind Up Telescopic Pole CML UPL Tactical Ladder



REBS Hook MaxGrip with Tactical Connector	
MBL (Inner two spikes)	1000 kg / 2204 lbs
Weight	1,3 kg / 2.9 lbs
Part no.	BE001720
Compatible with	Tactical Ladder CML Ultralight Pole Ladder



REBS Hook Dual 4" Titanium	
MBL (Tip)	1800 kg / 3968 lbs
Weight	1,2 kg / 2.4 lbs
Part no.	BE000331
Compatible with	Manual Telescopic Windup Telescopic Giraffe Tracer Ultralight Pole Ladder



REBS Hook Dual 6" Titanium	
MBL (Tip)	820 kg / 2204 lbs
Weight	1,28 kg / 3.3 lbs
Part no.	BE000211
Compatible with	Tactical Ladder CML Wind Up Pole Giraffe Tracer Telescopic Pole Ultralight Pole Ladder



REBS Hook Dual 8" Titanium	
MBL (Tip)	1000 kg / 2204 lbs
Weight	2,4 kg / 5.3 lbs
Part no.	BE000333
Compatible with	Manual Telescopic Giraffe Tracer Tactical Ladder Ultralight Pole Ladder



Tactical Adapter Shaft with Pigg	
MBL	1000 kg
Weight	0,36 kg / 0.8 lbs
Part no.	BE0008192
Compatible with	All tactical hooks



Tactical Adapter With Locking Pin	
MBL	1000 kg
Weight	0,68 kg / 0.8 lbs
Part no.	BE000357
Compatible with	All tactical hooks



Tactical Adapter Shaft w/ Ring fastening	
MBL	1000 kg
Weight	0,46 kg / 1 lbs
Part no.	BE0008120
Compatible with	All tactical hooks



Special Carabiner Hook	
MBL	1000 kg
Weight	0,08 kg / 0.17 lbs
Part no.	BE000018
Compatible with	Any hook w/ mounting bracket



REBS Urban Hook with Carabiner Mount	
MBL	550-1680 kg*
Weight	0,62 kg / 1.37 lbs
Part no.	BE000281
Compatible with	Ultralight Pole Ladder CML Tactical ladder Any other equipment with tactical interface



REBS Hook Dual 6,8" Tactical	
MBL (Tip)	1000 kg / 2204 lbs
Weight	1,8 kg / 4 lbs
Part no.	BE004514
Compatible with	Tactical Ladder CML Ultralight Pole Ladder



REBS Hook 7" Tactical	
MBL (Tip)	1000 kg / 2204 lbs
Weight	0,9 kg / 2 lbs
Part no.	BE004512
Compatible with	Tactical Ladder CML Ultralight Pole Ladder



REBS Hook 10" Tactical	
MBL (Tip)	1200 kg / 2204 lbs
Weight	1,1 kg / 2.4 lbs
Part no.	BE005746
Compatible with	Tactical Ladder CML Ultralight Pole Ladder



Locking Pin Release Assembly	
MBL	N/A
Weight	0,37 kg / 0.8 lbs
Part no.	BE002504
Compatible with	Any hook w/ mounting bracket



Pigg Release Assembly	
MBL	N/A
Weight	0,09 kg / 0.2 lbs
Part no.	BE002476
Compatible with	Any hook w/ mounting bracket



Ring Fastening Assembly	
MBL	1000 kg
Weight	0,14 kg / 0.3 lbs
Part no.	BE002516
Compatible with	Any hook w/ mounting bracket

TITANIUM GRAPNEL HOOKS COMPARISON

Titanium Grapnel Hooks are optimal for boarding, reaching a higher advantage point, or climbing and accessing buildings. Single and Dual titanium hooks are made of aerospace grade (Grade 5) titanium and are assembled with precision craftsmanship to ensure excellent strength and durability. All hooks are tested and approved prior to delivery. Used for both maritime and urban operations.

SINGLE HOOKS

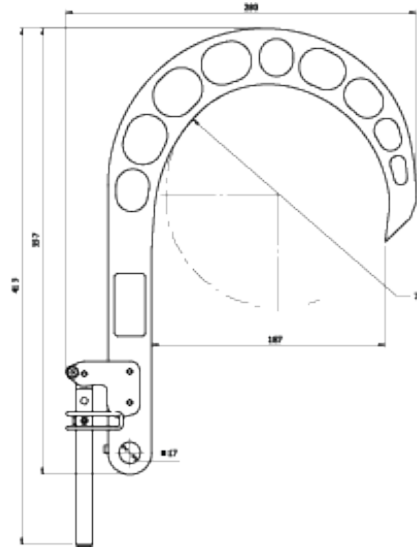

BE000212

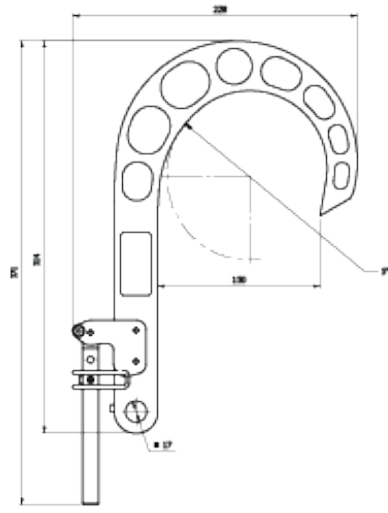

BE000332

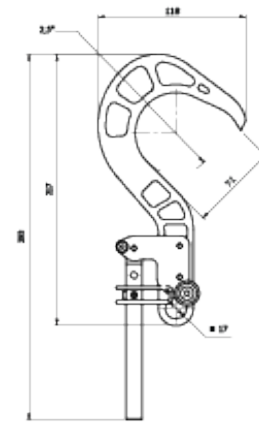

BE000352

DUAL HOOKS

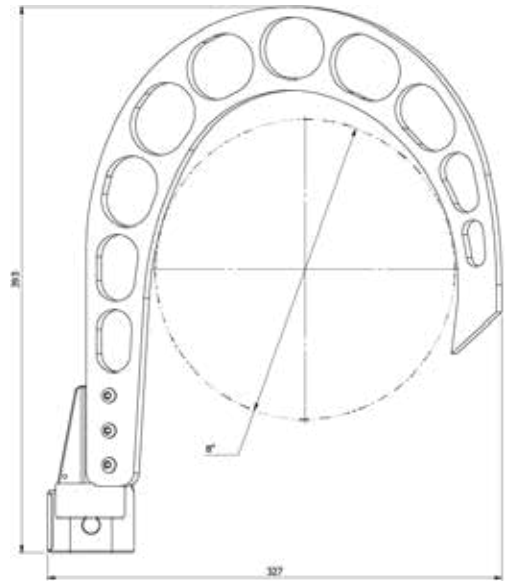

BE000333

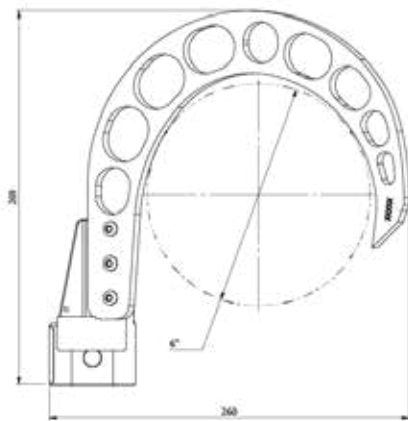

BE000211

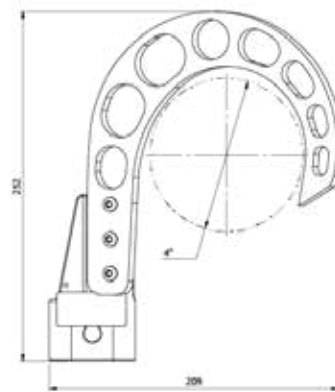

BE000331

CARBON FIBER HOOK (9.5")

The Carbon Fiber Hook was developed in collaboration with FFI (Norwegian Defense Research Establishment), H. Henriksen AS and the Norwegian Forces. The Carbon Fiber Hook is a state of the art high strength, low weight boarding hook designed to be used with the Telescopic Pole, Carbon Ladder, Giraffe Tracer or on the Windup Pole.

CARBON FIBER HOOK

The REBS® Carbon Fiber Hook is handmade. This ensures the highest quality throughout the production process.

Testing

All hooks are individually tested. The test program contains two load cycles. The first is a load gradually increasing to 800 kg (7,85 kN, 1764 lbs) and is then held constant for 30 seconds. The second load-cycle increases gradually to 1000 kg (9,81 kN, 2204 lbs) and is also held for 30 seconds at maximum load. Both load-cycles are run twice on each grapple. Testing is performed by FFI (Norwegian Defense Research Establishment).

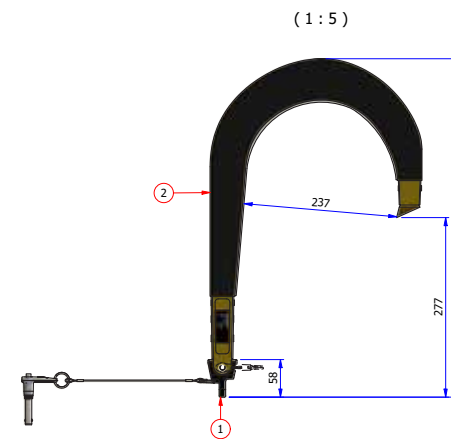

Specifications	
MBL (Tip)	1350 kg / 2976 lbs
Weight	1,1 kg / 2.4 lbs
Part no.	BE002436
Compatible with	Manual Telescopic Windup Telescopic Giraffe Tracer

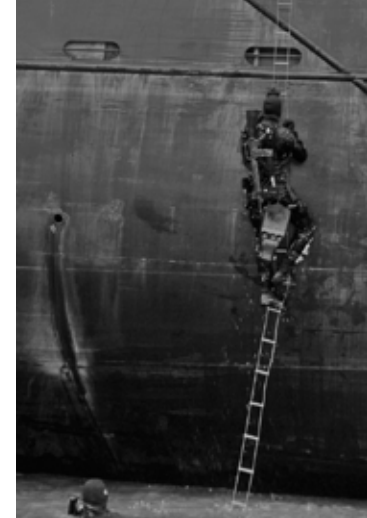
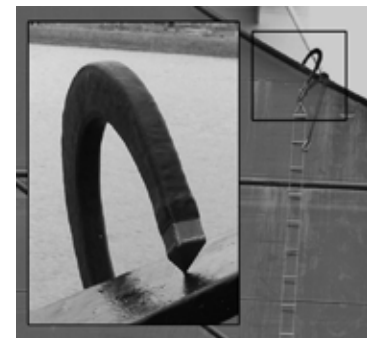

MAXGRIP HOOK

The MaxGrip Hook is a strong and practical hook made for urban use. Its intuitive design gives the user freedom to customize it for optimal use. The titanium/aluminium teeth give optimal grip and can dig in to almost every urban surface. You can attach the MaxGrip to both the tactical ladder and the pole systems.

The shape and design of the MaxGrip Hook makes it great for ledges, window frames and roof tops.

Specifications	
Maxgrip Hook with Pigg Release	BE001725
Weight	1,5 kg / 3.3 lbs
MaxGrip Hook with Tactical Connector	BE001720
Weight	1,3 kg / 2.9 lbs
Compatible with	Tactical Ladder, Carbon Ladder, CML, All telescopic poles

The two innermost spike rows and front spike tip are all made from grade 5 titanium and will penetrate even hard metal surfaces. The other spikes are made from high strength aluminum alloy that will also penetrate most hard surfaces. This ensures a very good grip on most surfaces and ledges.

All the teeth are easily replaceable.

The light weight high performance hook has a large maximum hook opening of 370 mm / 14,5" and will fit over a variety of different structures. It can also be collapsed into a compact volume for transportation. This makes it easy to pack and transport.

The holes along the side of the hooks allows the user to change the position of both connector and front spike in increments of 34 mm and thereby varying the hook opening. This makes the hook more efficient in several situations.

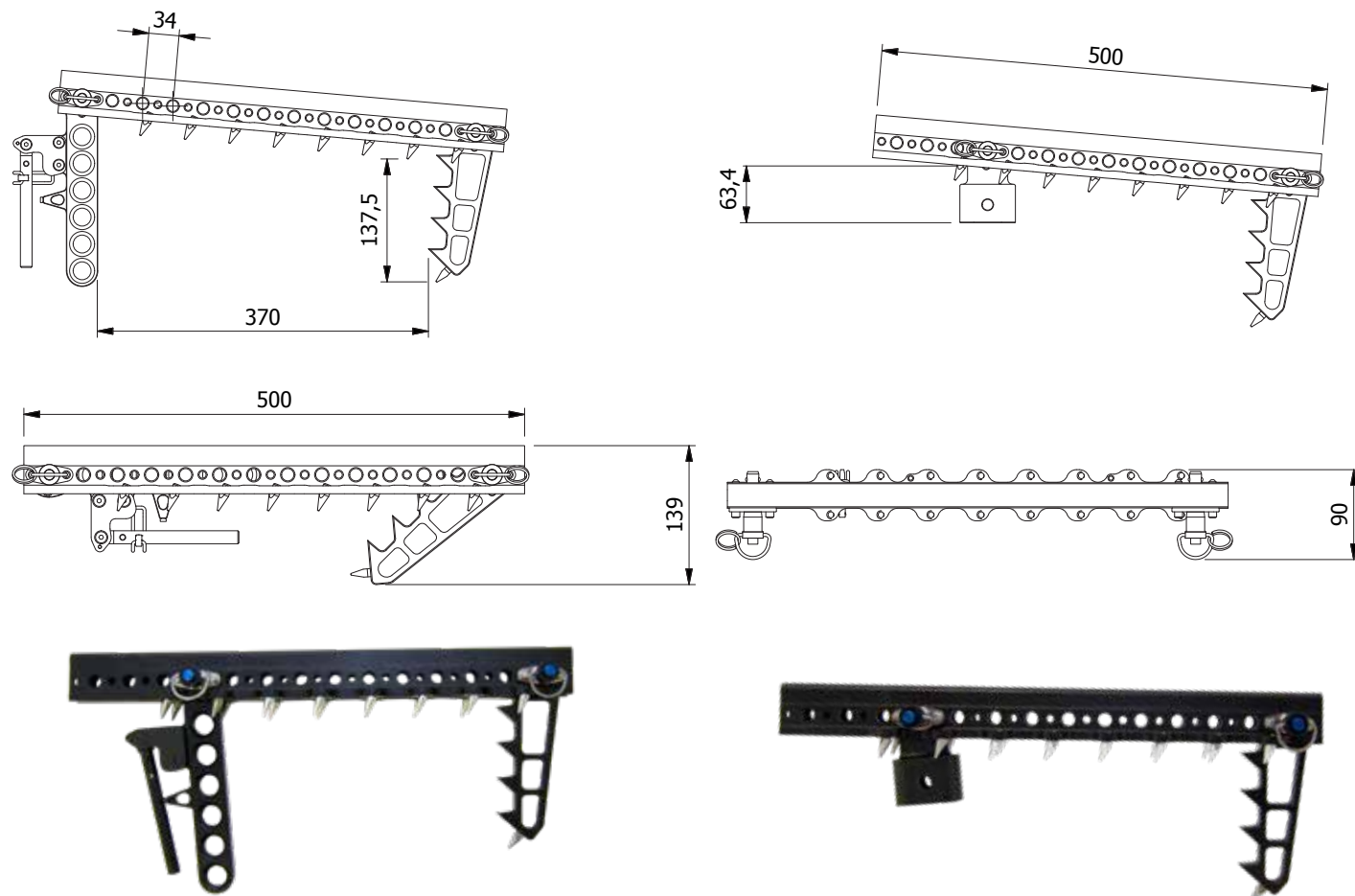

TACTICAL HOOK

Tactical hook is the name of our line of hooks which are extrusion forged in high quality aluminium to form a unique hollow strong and versatile hook. Used with the tactical adapter shaft it provides some really unique features.

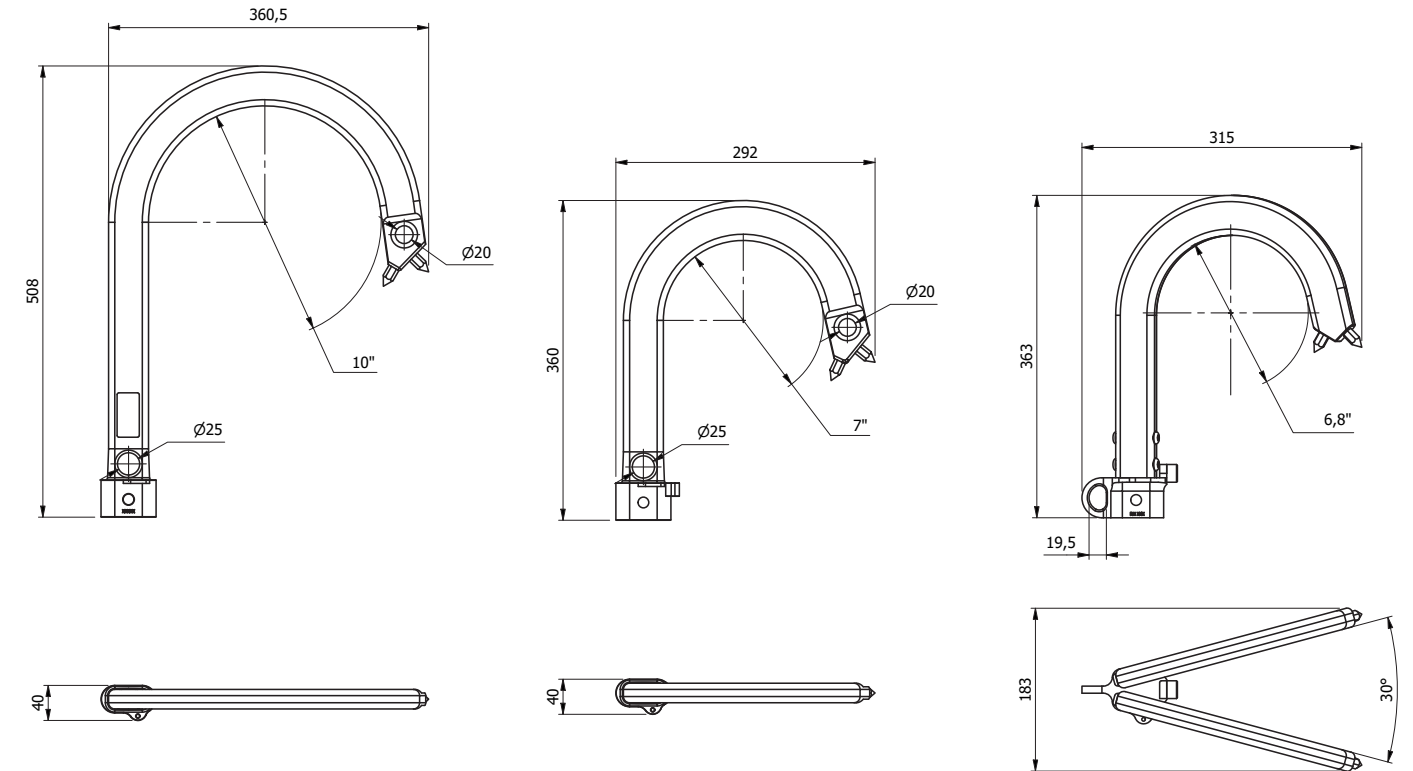

The smooth extrusion forged hollow body design of the tactical hook makes the hooks both light weight and strong. The hooks works great with any of our systems featuring a tactical connector.

Tactical Adapter Shaft

The latest development in the tactical hook range is the tactical adapter shaft, which now makes it possible to use the tactical hook with a pole and rope ladder. The tactical adapter shaft also has an anti-snag shape helps makes sure that the hook does not disconnect unintentionally. The tactical adapter shaft is a strong construction with a MBL rating of 1000 kg, and does consequently not reduce system MBL.

The tactical adapter shaft features a built-in ring fastening as well as the pigg release. This means that all conventional pole release techniques are available for the tactical hook range when combined with the tactical adapter shaft. The tactical adapter shaft enables the use of all pole release alternatives.

Tactical hook range			
Part Name	Part number	Weight	MBL (Tip)
REBS Hook 7" Tactical	BE004512	0,9 kg / 3.3 lbs	1000 kg
REBS Hook 10" Tactical	BE005746	1,3 kg / 2.9 lbs	1000 kg
REBS Hook Dual 6,8" Tactical	BE004514	1,8 kg / 4 lbs	1000 kg

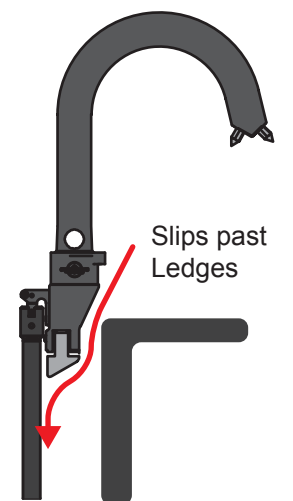

Tactical Adapter Shaft Anti-snag profile

REBS®

TACTICAL HOOK HANDLE

We have added a new handle, Tactical Hook Handle (BE000377) that is mounted at the base of our tactical hooks. The handle simplifies the transition “over the edge”. The handle is easily mounted by the operators and used mostly together with the UPL and tactical ladders, but can also be used together with the wire ladders.



SAFETY TACTICAL HOOK

The tactical hooks is equipped with an extra safety hole at the tip of the hook. The hole is used to attach safety on the hook when climbing. During training we always recommend the operators to attach safety line to the system, and this hole will always be easily accessible for attaching a safety line.



REBS®

URBAN HOOK

The Urban Hook is a strong and practical hook made for urban climbing. Its intuitive design gives the user freedom to customize it for optimal use. The high-strength steel tips and teeth give optimal grip and can dig in to almost every urban surface: Concrete, metal and wooden materials, including when container locks are engaged. This is excellent to use with 2-3 UPL sections in Urban climbing.



Urban Hook opened / closed with Carabiner Mount BE000281



Urban Hook with Tactical Adapter BE000283

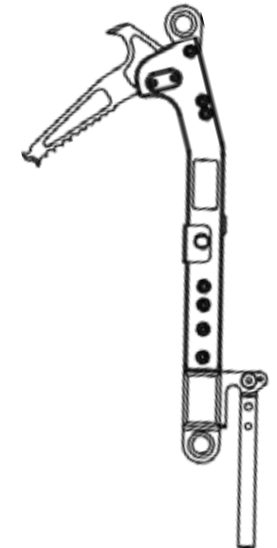

Urban Hook with Pigg Release BE000282

Load types:

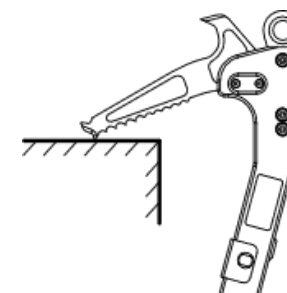

Pick

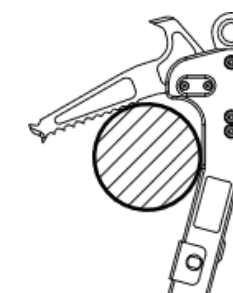

Arc



Skyhook

POLES



REBS®

SKYPOLE

NEW!

REBS is already supplier of a similar pneumatic pole system with a reach of 15m, called the Giraffe Tracer. We have been the world distributor of this system for many years and have extensive experience with more than 160 systems sold. The 20m system is a newly developed system based on this extensive experience.

The pole is typically used from a Rigid Inflatable Boat (RIB) to place a hook and ladder on a larger ship, but can also be used in other situations on other structures including on land.

The Sky Pole is made of edge breaking carbon fiber technology from automotive industry gives unique stiffness and ruggedness to the tubes. This increases the operational safety and effectiveness. Selected materials are optimized to give low weight and the centre of gravity is designed to be lowest possible.

The hook is safely locked in place while extending the pole. When pressure in the pole is reduced ie. retracting the pole, the hook is unlocked and releases easily. This gives the opportunity to release the hook while the pole is standing vertically.

The new locking mechanism avoids the hook to fall off due to harsh operational conditions and accidentally fall down.



A new Handle is developed for the Sky Pole.



REBS®

SKYPOLE STANDARD PACKAGES

We supply SkyPole in complete packages with the most common components, but we also make custom packages on request for specific orders.

REBS SkyPole Packages		15M LW BE000472	20M HD BE000471
Part name	Part no.	Pcs.	Pcs.
REBS SKyPole 15M LW	BE000432	1	-
REBS SkyPole 20M HD	BE000243	-	1
REBS Hook 13" Tactical	BE000435	1	1
SkyPole Hook Flexi Adapter	BE000414	1	1
Bottle 3,0 liter 300 bar	BE003431	1	-
Bottle Twin 2 x 6,75 liter 300 bar	BE003475	-	1
SkyPole Air Regulator 200/300 bar	BE003355	1	1
REBS Wire Ladder 15M	BE002462	1	-
REBS Wire Ladder 20M	BE002463	-	1
REBS Ladder Reel	BE005538	1	1
Wire Ladder Protector	BE000461	1	1
Fifi Ladder Hook	BE002459	1	1
Distance Wheel	BE000085	6	6
Wire Protection	BE000461	2	2
Baseplate Assembly 200 x 200 mm	BE003361	1	-
Pole Rail Stand	BE000421	-	1
Transport Bag	BE000469	1	1
SkyPole Maintenance Tool Kit	BE000436	1	1
REBS Poleman Harness	BE000036	1	-

Specification Sky Pole		
	15M LW	20M HD
Article number:	BE000432	BE000243
Top Section (mm)	34	44
Bottom Section (mm)	64	84
Extended Length(m/ft)	15M/49,2FT	20M/65,FT
Collapsed Length(m/ft)	4,7M/15,4FT	5,2M/17FT
Operational weight	Appr. 15 KG	Appr. 24 KG
Full extension	8 - 10	10 - 12
Full retraction	4 - 5 s	6 - 8 s

We are able to deliver the Sky Pole up to 24 M upon request.



13" Aluminium Hook

The Skypole makes it possible to lift even heavier tools, larger ladders, even rigid ladders. The New 13" Aluminium Hook suits this well.

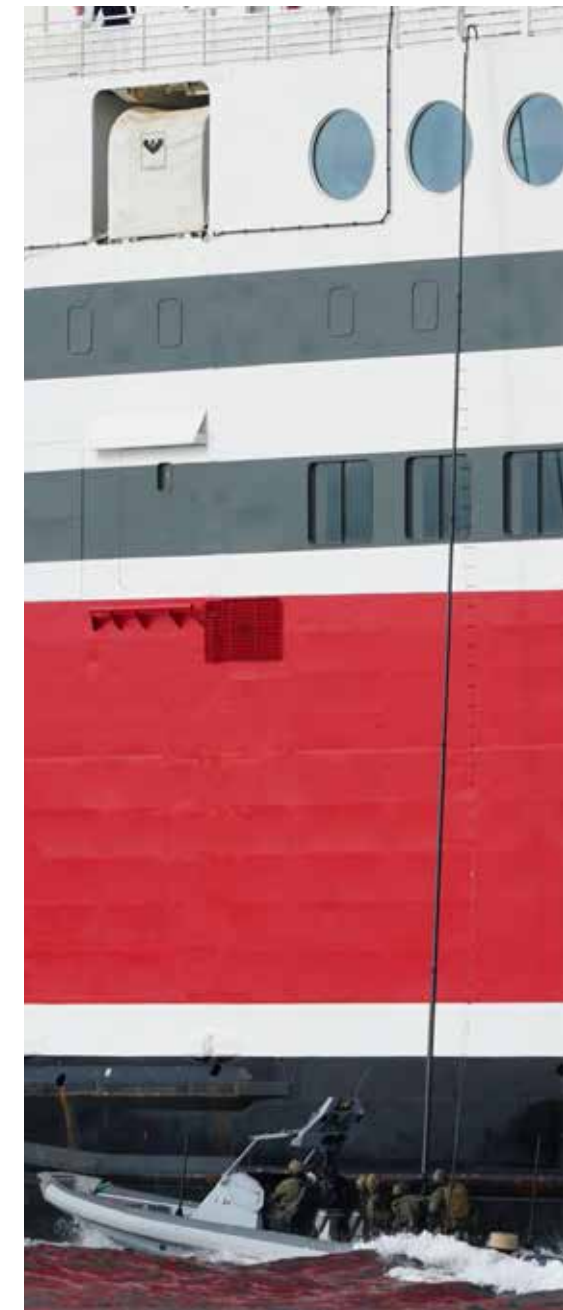

REBS®

POLE RAIL STAND

The Pole Stand and the Pole Rail Stand are designed to assist with the handling of the REBS SkyPole and the Giraffe Tracer Pneumatic Pole under operational conditions. The stands allow the poles to be moved within a safe and restricted area of movement, and to be parked securely in its center position.

Pole Rail Short
BE000395

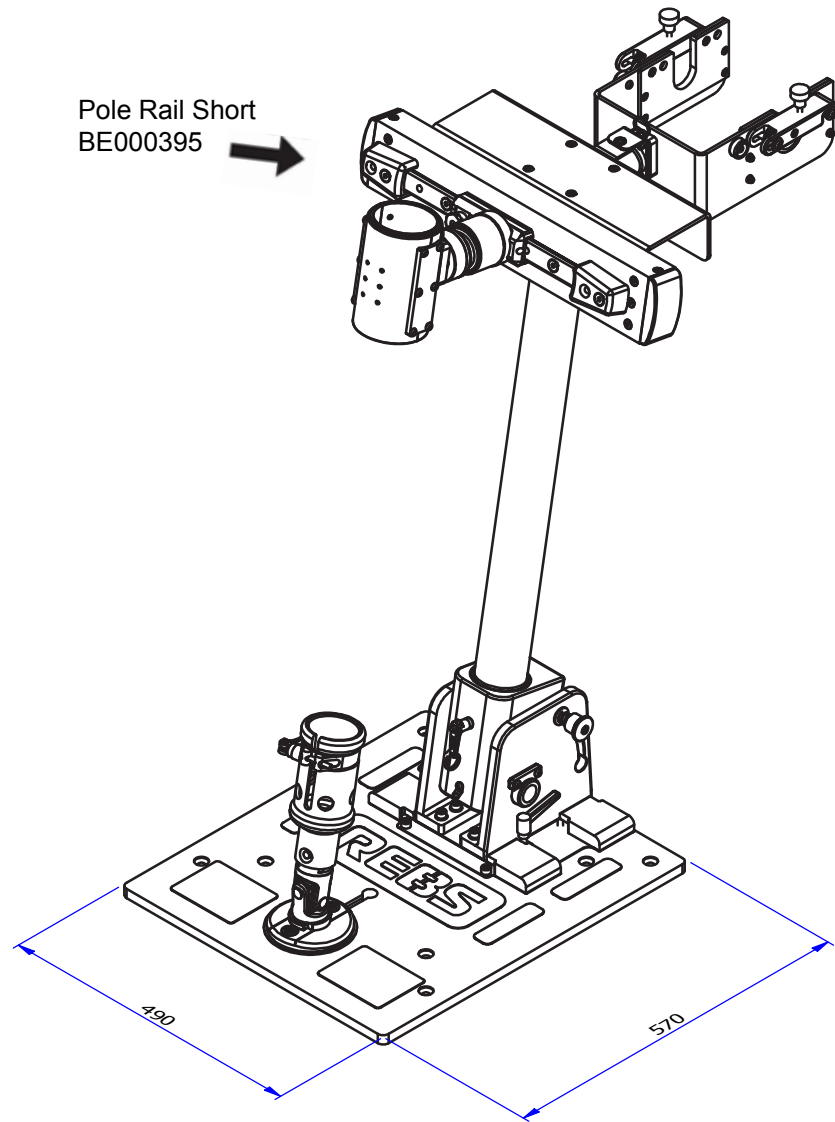

BE000421

Specifications	
Part no.	BE000421
Length	1000 mm
Width	490 mm
Weight	45,7 kg

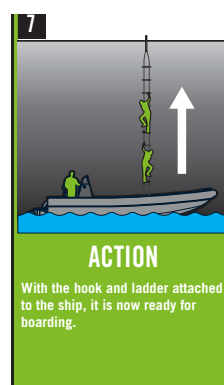
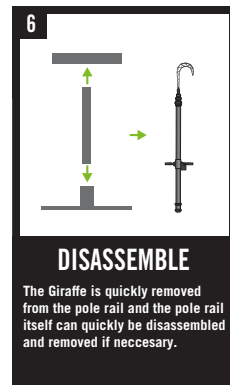
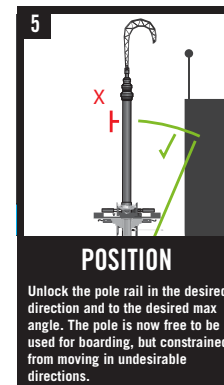
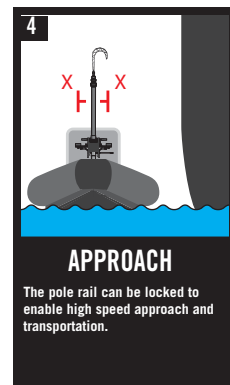
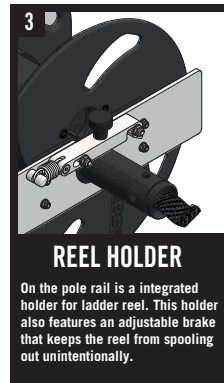
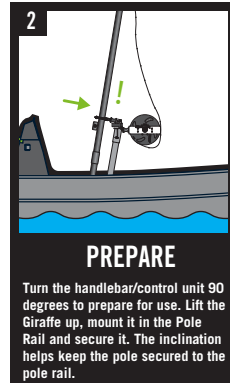

REBS®

ROLATUBE

The Rolatube is made from an innovative low weight bistable composite material that can be coiled into a very compact roll. Roll out the Rolatube and it instantly snaps into a long rigid pole. The Rolatube is a versatile tool that can be used in boarding, urban operations, and beyond. It is suitable as a stop mast, a signal mast, for surveillance, or any other uses where a portable, compact and collapsible pole is needed.



COMPOSITE STRUCTURE THAT ROLL-UP

For the top end of the Rolatube, the custom made top adapter can be supplied with either 2,5" or 5" Titanium Hook attached. The Rolatube hook adapter releases from the Rolatube pole after the hook is placed. The adapter also allows the hook to be repositioned and removed by using the Rolatube pole. Combining the Rolatube pole with the top adapter and the 5 / 7 m (16.5 / 23 ft) wire ladder results in a very portable climbing system with great versatility, low weight, and excellent reach.



The Rolatube packages allow users to reach entering points exceeding 7 m in height. The packages are extremely compact and lightweight when stored and easily fit into a backpack.

The Rolatube can be used in many situations and for different purposes besides boarding. It is suitable as a stop mast, a signal mast, for surveillance, or any other uses where a portable, compact and collapsible pole is needed.

Rolatube 3 m Backpack Package		BE003654
Part name	Part no.	Pcs.
REBS Rolatube 2,5" 3 m Black	BE003658	1
REBS Wire Ladder 5 m	BE002420	1
REBS Hook 2,5" Titanium with Rolatube L adapter	BE000356	1

Rolatube 5 m Backpack Package		BE003655
Part name	Part no.	Pcs.
REBS Rolatube 2,5" 5 m Black	BE003540	1
REBS Wire Ladder 7 m	BE002538	1
REBS Hook 5" Titanium with Rolatube L adapter	BE000363	1
Bag	BE002506	1



REBS®

TELESCOPIC POLE

The Telescopic Pole is a versatile and robust tool for many different purposes. Available in various versions and lengths, with diverse adapters to suit any type of operation. Custom made adapters are available on request.

The manual telescopic pole consists of multiple carbon fiber segments telescoping into each other. At the end of each segment is a quick-action clamp with a lever that securely locks the internal segment in place. Pivot the lever to open position, and the internal segment is free to move. Adjust the pole segment to a set length and push the lever back down into the locked position. Repeat for all the segments to extend the pole to the desired length.

The height of the collapsed pole determines which situations it is most suitable. The poles up to 6 ft. are easy to manage by a single operator on dry land or a boat, and are great tools for boat-to-boat boarding. The longer poles are made for diving and are easy to use and extend from within water, or to reach the top of a building on land.

The manual telescopic poles are made from carbon fiber, polyamide, and anodized aluminum which provide excellent salt water resistance. Telescopic systems should be cleaned with fresh water after operation at sea to ensure proper functionality over their lifetime.

The poles come in several different lengths and versions, see the next page for more information.



REBS®

TELESCOPIC POLE - DETAILS

Part no.	Name	Collapsed length	Full length	Weight	Sections
BE002404	2,8 m	0,8 m / 2.7 ft	2,9 m / 9.6 ft	0,85 kg / 1.9 lbs	6
BE002473	6,8 m	1,2 m / 4.0 ft	6,8 m / 22.3 ft	2,35 kg / 5.2 lbs	9
BE004834	8 m	1,9 m / 6.1 ft	8,0 m / 26.3 ft	3,5 kg / 7.7 lbs	5
BE002464	9 m	1,9 m / 6.1 ft	9,2 m / 30.1 ft	4 kg / 8.8 lbs	6
BE002465	10 m	3,6 m / 11.7 ft	10,1 m / 33 ft	3,8 kg / 8.4 lbs	3
BE004835	12 m	2,7 m / 9.1 ft	12 m / 39.3 ft	5,6 kg / 12.3 lbs	5
BE002466	15 m	3,3 m / 10.8 ft	15 m / 49.2 ft	5,9 kg / 13 lbs	5

(Measurements rounded to first decimal)

TELESCOPIC POLE - PACKAGES

REBS Micro Boarding Package 1		BE004300
Part name	Part no.	Pcs.
REBS Hook 2,5" Titanium with Pigg Release	BE002526	1
REBS Telescopic Pole 2,8 m Carbon Fiber	BE002404	1
REBS Rope Ladder 6 m	BE004206	1

Additional: Bag: BE294813

REBS Boarding Package Set 1		BE002180
Part name	Part no.	Pcs.
REBS Hook 7" Titanium with Pigg Release	BE000212	1
REBS Telescopic Pole 9 m Carbon Fiber	BE002464	1
REBS Wire Ladder 10 m	BE002461	1

Additional: Bag BE003340



All our poles are delivered in a durable nylon bag. BE003340

Pictured is our most compact pole. Extending from 0,75 m to 2,8 m and only weighs 0,85 Kg.



REBS®

WINDUP POLE

The Windup Pole is a high-performance, 15 m windup action telescopic pole. It is compact, fast and strong and designed for use both on land and at sea. The main difference compared to the manual telescopic poles is the windup control which means that the pole needs less handling and is under certain conditions much easier to extend.

The Windup Pole is a telescopic pole with a manually operated winch and belt system to extend it.

All parts of the Windup Pole are designed for both land and sea use, and withstand immersion in sea water. The telescoping tubes are made from high strength hybrid carbon fiber composite.

The top adapter of the pole is compatible with all of our grapple hooks with the hulk adapter. Similar to the manual telescopic poles, the windup pole is used for placing a hook with an attached ladder or rope onto a ledge or railing.

The windup pole is extended while in vertical position for easy operation.



The Windup Pole has an automatic brake which keeps the pole from collapsing unintentionally. It also features both wind-up and wind-down action which, in certain cases, is absolutely necessary in order to retract the pole.

All belts and moving parts are contained inside the pole for a reliable system with few pinch points.



BE000211
REBS Hook Dual 6" Titanium Tactical

Specifications	
Reach (extended)	15 m / 49 ft
Retracted length	4,1 m / 13.45 ft.
Weight	15,8 kg / 34.8 lbs

Rebs Windup Pole Packages		BE006841 (with 6" Dual Titanium Hook)	BE006840 (with 9.5" Carbon Fiber Hook)
Part	Part no.	Pcs.	Pcs.
REBS Windup Pole 15 m TLP61/15-4.2	BE000025	1	1
Baseplate Assembly	BE002303	1	1
REBS Hook Dual 6" Titanium Tactical	BE000211	1	-
Tactical Adapter Shaft with Locking Pin	BE000357	1	-
REBS Hook 9,5" Carbon Fiber	BE002436	-	1
Locking Pin Release Assembly	BE002504	-	1
REBS Wire Ladder 15 m	BE002462	1	1
Wire Ladder Protector	BE000461	1	1
Bag	BE003349	1	1
REBS Ladder Reel	BE005538	1	1
REBS Distance Wheel	BE000085	6	6
REBS Poleman Harness	BE000036	1	1

REBS®

GIRAFFE TRACER PNEUMATIC POLE

The Giraffe Tracer is a pneumatic powered extension and retraction pole for boarding and entering. The Giraffe Tracer is available in two different lengths: 3,3 m retracted / 10 m extended (11 ft retracted / 33 ft extended) and 4,4 m / 15 m (14,5 ft / 50 ft). The Giraffe features an easy to use pneumatic system with push button control for precision up and down movements. The control handle is collapsible and adjustable to retain a slim profile when not in use.

OPERATION

Use the push-buttons to activate the efficient pneumatic system. Thanks to the simple controls the operator can concentrate on the aiming and timing aspects of the operation. Key performance numbers for the two poles lengths are:

Performance		
Length	Full extension	Full retraction
10 m / 33 ft	6 s	8 - 11 s
15 m / 50 ft	8 s	11 - 14 s

The retraction button has two speeds: push it half-way in to release the pressure and let gravity retract the pole. If more force is required, push the retraction button completely to activate the vacuum system to quickly retract the pole.

The rapid action eccentric handle lock is prepared for use or collapsed into transportation-position in a few seconds. The versatile baseplate(s) are available in multiple sizes to allow the pole to be attached to nearly any location, such as the deck of a RIB.

The outer surface of the pole tubes are smooth to reduce friction, noise, and ensure efficient extension and retraction.

The air that is released during retraction is dampened by dual silencers. The bottom mount on the pole is designed for the most common boat deck mountings with a diameter of 63,5 mm (2,5 in).

The baseplate allows the pole to be attached to e.g. the deck of a RIB, and is delivered in multiple sizes.

BUILD QUALITY

Lightweight tubes are constructed from unidirectional pre-impregnated carbon fiber, built for the highest strength and stiffness with the lowest possible weight. All metal parts are made of stainless steel or hard anodized 6061-T6 aluminum. All threaded holes have stainless steel inserts for long operational life.

Specifications	
15 m Tracing height	15 m / 49.2 ft
15 m Storage length	4,4 m / 14.4 ft
15 m Weight	13,5 kg / 29.8 lbs
10 m Tracing height	10 m / 32.8 ft
10 m Storage length	3,3 m / 10.8 ft
10 m Weight	10,9 kg / 22.9 lbs
OD Bottom Tube	Ø72 mm / 2.8"
Hook weight w/ release	1,7 kg / 3.7 lbs



GIRAFFE TRACER PNEUMATIC POLE - DETAILS



SAFETY SYSTEM

The standard solution is a rigid hook-attachment but also available is this spring loaded twisting system that reduces bending moments to the system in the case the hook "collides" sideways during the operation.

UP AND DOWN

The challenge with pneumatic tubes are getting them down. The REBS Giraffe-Tracer™ has an extremely efficient vacuumed system for retracting the telescopic pole.

CONTROL UNIT

The control unit is designed to be intuitive and fast to use. Push the up-button to extend. Depress the down-button halfway to release the air pressure, or fully to activate the vacuum system.

SAFETY LOCK

The hook is designed so that it must be bent backwards to release it from the pole. This happens naturally as the pole is pulled away when the hook has attached to the railing.

SPEED

Speed and simplicity of the operation is essential - to be able to erect the pole as late as possible can be critical. The REBS Giraffe-Tracer™ Pole erects in just 8 seconds and retracts in only 11 seconds.

NON-ROTATING

The tube-profiles interlock, stopping the individual segments from rotating independently. This gives the operator greater control of the hook during an operation.

EXTENDED STRENGTH

The hook is able to handle extreme situations and can hold over 1000kg when hanging by the tip alone. The tip is a sharp hard metal insert that digs into most surfaces.

ROTATING HANDLE

For easy transport and stow away, the REBS Giraffe-Tracer™ is equipped with a rotating handlebar. This enables great control during operation and a small form factor during transport.

ADJUSTABLE HANDLE

The handle is easily adjusted in height to accommodate different operators and scenarios.

AERODYNAMIC HOOK

The REBS Giraffe-Tracer™ hook has an open triangle trusswork which, in addition to being a strong and lightweight design, makes the hook aerodynamic when exposed to wind, minimizing the twisting of the hook in the wind.

FLEXIBLE BASE PLATE

The REBS Giraffe-Tracer™ pole is delivered with a flexible pole mount for enabling the pole to be positioned easily.

ENDURANCE

The REBS Giraffe-Tracer™ carbonfibre tubes are noncorrosive and thus have a long life time, all air seals are easy to maintain and service.

GIRAFFE TRACER PNEUMATIC POLE STANDARD PACKAGES

We supply the Giraffe Tracer in complete packages with the most common components, but we also make custom packages on request for specific orders.

REBS Giraffe Tracer Packages		10 m BE006701	15 m BE006700
Part name	Part no.	Pcs.	Pcs.
REBS Giraffe Tracer 10 m	BE003632	1	-
REBS Giraffe Tracer 15 m	BE003345	-	1
REBS Hook for Giraffe Tracer	BE003346	1	1
Air Regulator 200/300 bar	BE003352	1	1
Bag 10 m	BE004549	1	-
Bag 15 m	BE003349	-	1
Mounting Brackets	BE003350	1	1
REBS Wire Ladder 10 m	BE002461	1	-
REBS Wire Ladder 15 m	BE002462	-	1
Baseplate Assembly 200 x 200 mm	BE003361	1	1
Bottle 3,0 liter 300 bar	BE003431	1	1
REBS Ladder Reel	BE005538	1	1
REBS Poleman Harness	BE000036	1	1
Maintenance Kit	BE008068	1	1

Optional extras

Part Name	Part no.
Bottle Twin 6,75 liter 300 bar	BE003475
Baseplate Assembly 490 x 490 mm	BE006132
REBS Wire Ladder 5 m	BE002420
Hose Extension 2m	BE390191
Hose Extension 5m	BE390194
Swivel Joint	BE000263
Pole stand	BE000218

1

TRANSPORT

With the REBS Giraffe-Tracer™ Pneumatic Pole properly secured for transport, maneuver the boat to the desired location.

2

PREPARE

Mount the hook on the top of the pole and turn the handlebar / control unit 90 degrees to prepare for use.

3

ERECT

With its flexible baseplate and suitable mounting, the pole can be erected in a matter of seconds. Release the transport mounts and simply rise the pole.

4

POSITION

Assume position behind the control unit.

5

EXTEND

The extend button activates the pneumatic system which extends the pole.

6

PLACE

Use the handlebars and the extend/retract buttons on the control unit to place the hook in the desired location.

1

FASTEN

Place the hook on a suitable ledge.

2

PULL

The hook is fastened to the pole with a security latch. When hooked to the ledge, retract the pole to disengage the hook. Pull the ladder downwards to help release if necessary.

3

RELEASE

When the required angle is reached, the hook is released from the pole. The hook and ladder are now free from the system and attached to the ship.

1

RETRACT

The REBS Giraffe-Tracer™ pole has an effective vacuum system that can rapidly retract the pole. Press the retract button on the control unit to retract.

2

COLLAPSE

Collapse and secure the pole with its transport mounts.

3

ACTION

With the hook and ladder attached to the ship, it is now ready for boarding.

LAUNCHER



REBS®

REBS LAUNCHER

The REBS Launcher enables users to access high-up entry points by launching a grapnel hook on to a permanent fixture and then ascending ropes fixed from that point. The Launcher is perfect for entering buildings, bridges, ships, platforms or cliffs as well as crossing ravines or rivers, both for military and rescue scenarios.

The REBS Launcher is designed in close co-operation with the Norwegian Forces.

The REBS Launcher is powered with pressurized air, which facilitates low noise operation and enables easy reloading from ordinary diving bottles.

The grapnel hooks in high strength aluminum alloy and titanium reach distances of 50 meters height and a horizontal distance of 100 meters. A climbing ladder can be launched as high as 25 meters. The power of the launcher can be preset on the fly by adjusting the pressure using the pressure gauge.

The Launcher can be used several times at various heights for each tank refill. The number of shots between refills depends on the pressure used for each shot.



The Launcher Piston Kit reduces both recoil and sound levels, providing both tactical and HSE benefits. It is easily installed on existing units, and is also recommended as a standard part on new deliveries. Contact us for more information.

For ease of transportation and increased comfort at very high pressures we provide a REBS Launcher stand platform which can be bolted to any flat surface and we also provide custom interfaces for any boat or vehicle.



A flexible solution is the Launcher Mount that can be used both with a flexible padded base, or a the rubber pad. Allowing the Launcher to be fired safely even while rested on the ground.



Specifications

Maximum height with grapnel	50 m / 164 ft
Maximum height with rope ladder	25 m / 82 ft
Maximum length with grapnel	100 m / 328.1 ft

Shoot with the REBS Launcher from a ground supported position with the Launcher Mount Kit (BE000113).

REBS LAUNCHER SYSTEM OVERVIEW MOST COMMON PARTS

REBS Launcher
BE002442



System for External Bottle V.2
BE003752



Piston Kit
BE000038



Storage Box
BE002480



Bottle 1,0 liter Composite
BE003711



Rope/Ladder Container V.2
BE003674



REBS Web Ladder for Launcher 25 m
BE002561



REBS Grapnel
BE002513



REBS Rope Ladder 25 m
BE002477



REBS Rope DYNEEMA ø8 mm 50 m Black
BE002507



Mount Kit
BE000113



Toolset
BE002537



REBS Launcher Single Platform
BE007374



Fill Line Valve V.2
BE004009



LAUNCHER - STANDARD PACKAGES

REBS Launcher packages		Tactical Package 1 BE000163	Tactical Package 2 BE000164
Part name	Part no.	Pcs.	Pcs.
REBS Launcher	BE002442	1	1
Piston kit	BE000038	1	1
Bottle 1,0 liter Composite	BE003711	1	2
Rope/Ladder Container V.2	BE003674	1	1
REBS Grapnel	BE002513	1	4
REBS Rope DYNEEMA ø8 mm 50 m Black	BE002507	1	1
Toolset	BE002537	1	1
Fill Line Valve V.2	BE004009	1	1
System for External Bottle V.2	BE003752	1	1
Storage Box	BE002480	1	1
REBS Web Ladder for Launcher 25m	BE002561	1	1
REBS Rope Ladder 25 m	BE002477	1	1

Detailed Specifications

Bore	67 mm / 2.6"
Length	1070 mm / 42.1"
Weight (without grapnel and rope)	7 kg / 15.4 lbs
Grapnel length	250 mm / 9.8"
Grapnel weight	1200 gram / 2.6 lbs
Standard grapnel MBL (tip)	600 kg / 1323 lbs
Pressure air bottle	1 liter / 300 bar
Grapnel maximum height (vessel position)	Rope Ø8 mm / 0,32": 50 m / 164 ft (vertical)
Grapnel maximum distance (man held position)	Rope Ø6 mm / 0,24": 100 m / 328 ft (horizontal)
Grapnel maximum height (vessel position)	Rope Ladder : 25 m / 82 ft (vertical)
Capacity rope container	2 x 50 m Ø6 mm / 2 x 164 ft Ø0,2"
Rope size	Ø6 - 11 mm / Ø0.2 - 0.4"
Rope ladder length	25 m / 82 ft

LAUNCHER - SPECIFICATIONS

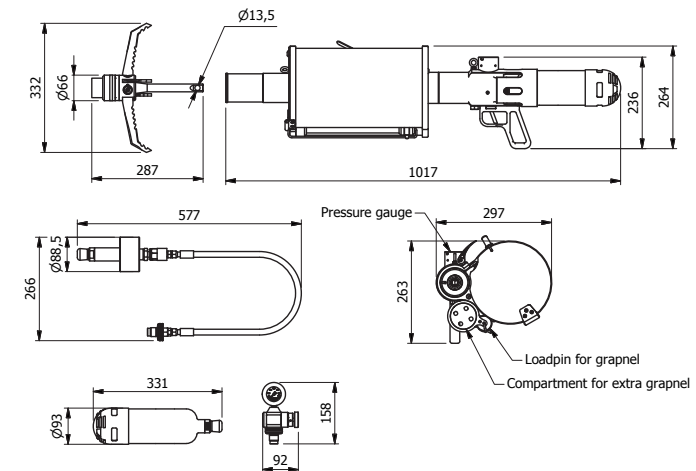

REBS®

COMPACT LAUNCHER V.2

The Compact Launcher is a smaller version of the larger REBS Launcher, and has been developed for more versatile use than the big brother. Whereas the REBS Launcher is designed to be the ultimate boarding tool with unmatched performance, the Compact Launcher is designed to be a light weight, compact in size line thrower for many different applications.

The Compact Launcher is a high performance pneumatic launcher that has been designed for use in maritime and urban environments. The Compact Launcher grants high reliability, reach and versatility.

Based on end user experience from the bigger REBS® launcher and customer requests, the Compact Launcher with collapsible stock was designed. The system is very effective to use in many scenarios including diving, boat-based and land-based climbing operations.

The Compact launcher is powered by pressured air and the 0.35 L bottle can be easily be re-filled from a normal 300 bar diving bottle. Lower pressure diving systems can also be used to charge the tank. Users can set the firing pressure on the fly depending on the height needed. A compact rope container can be mounted on the barrel and fits 115 ft of 8 mm rope or 53 ft of rope ladder. Multiple shots can be fired from a single bottle charge.

The Compact Grapnel with spring-loaded folding arms will hook into any object such as wire, fences, railings, and structural and natural features. It can be used to deploy a climbing rope, flexible ladder or a horizontal traverse line.

The Piston Kit upgrade reduces both recoil and sound levels, providing both tactical and HSE benefits. Contact us for more information.



It is easy to maintain and has a long and robust service life with proper post operations care. The Compact Launcher leverages the 12+ years of operational service and lessons from its "big brother".

The Compact launcher is available in several kit options. A custom made transportation and storage box makes the Compact Launcher highly transportable and user friendly.



Specifications	
Maximum height with grapnel	35 m / 114.8 ft
Maximum height with rope ladder	16 m / 52.5 ft

REBS®

COMPACT LAUNCHER SYSTEM OVERVIEW

MOST COMMON PARTS

REBS Compact Launcher
BE000083



Maintenance Kit
BE004878



Piston Kit
BE000057



Fill Line Valve
BE004263



Bottle 0,35 liter Aluminium
BE004204



REBS Web Ladder for Launcher 25 m
BE002561



Rope/Ladder Container
BE004262



REBS Rope Ladder 16 m
BE002458



REBS Grapnel
BE007838

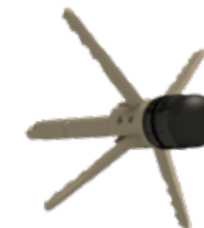

Compact launcher Carry System
BE000400



REBS Rope DYNEEMA ø8 mm 40 m Black
BE004343



COMPACT LAUNCHER STANDARD PACKAGE

REBS Compact Launcher packages		Standard Package BE000165
Part	Part no.	Pcs.
REBS Compact Launcher	BE000083	1
Piston Kit	BE000057	1
Bottle 0,35 liter Aluminium	BE004204	1
Rope/Ladder Container	BE004262	1
REBS Grapnel	BE007838	2
REBS Rope DYNEEMA ø8 mm 40 m Black	BE004343	1
Maintenance Kit	BE004878	1
Fill Line Valve	BE004263	1
Web Ladder for Launcher	BE002561	1
REBS Rope Ladder 16 m	BE002458	1
Compact Launcher Carry System	BE000400	1

COMPACT LAUNCHER CARRY SYSTEM

The Compact Launcher Carry System is developed to make it easier to carry the Compact Launcher during operations. With this bag you may easily bring the Compact Launcher as a backpack or a bag, This also suits into the hard Storage Box.



The Bag contains everything you need for an operation.



Soft Bag that fits within the Storage Box



Spareparts, Grapnels, Maintenance Box and Fill Line Valve are below the bag in the box.



The Storage Box

COMPACT LAUNCHER SPECIFICATIONS

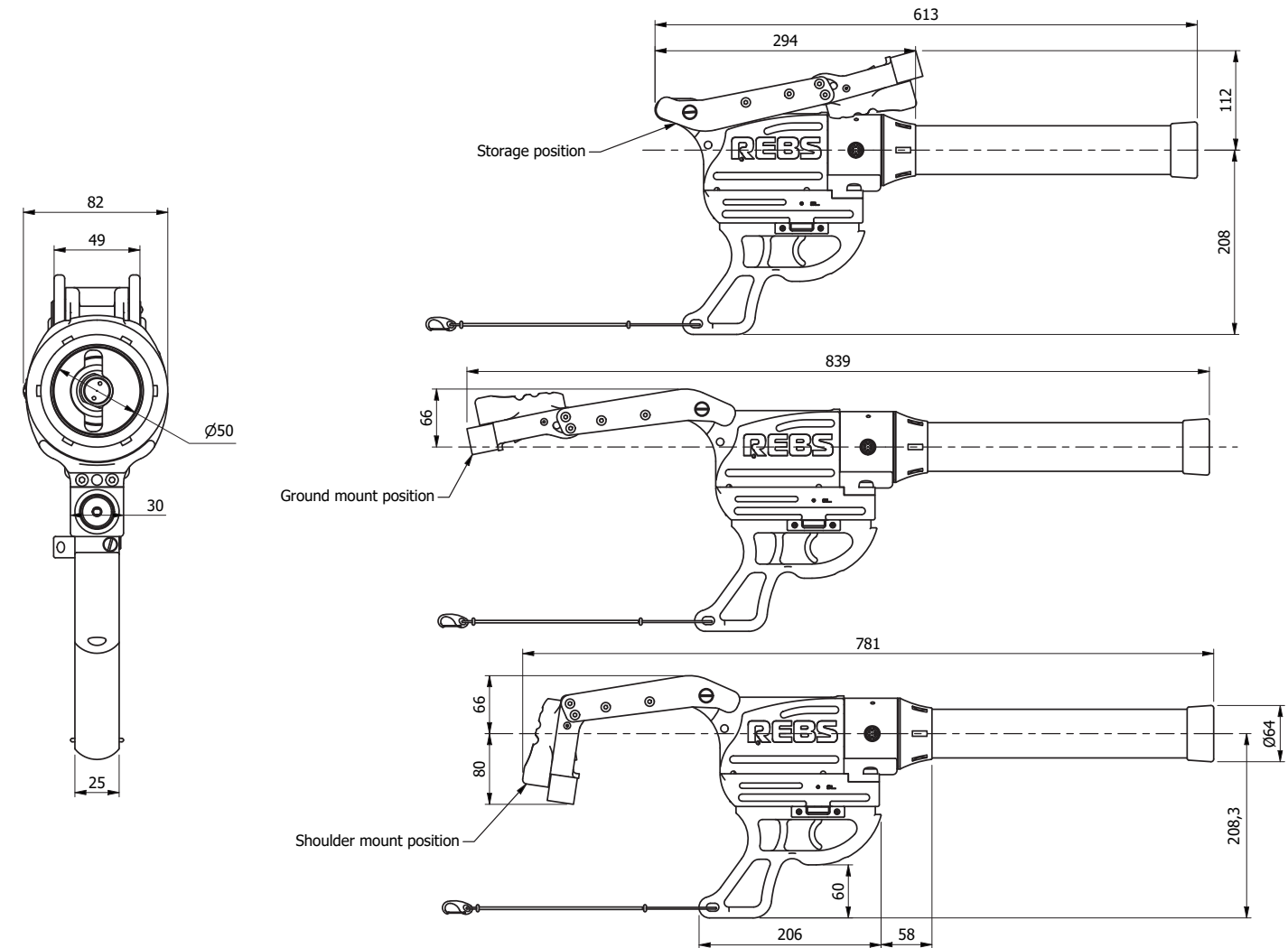

Specifications	
Bore	50 mm / 2.17"
Length assembled with stock out	839 mm / 33"
Weight (without grapnel and rope)	4,4 kg / 9.7 lbs
Standard grapnel length	252 mm / 9.92"
Standard grapnel weight	792 gram / 1.75 lbs
Standard grapnel MBL (tip)	420 kg / 926 lbs
Pressure air bottle	0,35 liter / 300 bar
Grapnel maximum height (vessel position)	Rope Ø8 mm / 0,32": 35 m / 114.83 ft (vertical)
Grapnel maximum distance (man held position)	Rope Ø6 mm / 0,24": 60 m / 196.85 ft (horizontal)
Grapnel maximum height (vessel position)	Ladder : 16 m / 52.5 ft (vertical)
Capacity rope container	Ø6 mm : 2 x 30 m
Rope size	Ø6 - 11 mm / 0.2 - 0.4"
Rope ladder length	16 m / 52.5 ft

ATLAS POWERED ASCENDER APA-5

Lightweight and powerful, the Atlas Devices APA-5 is a multi-mission device that hauls combat rescue loads, extends warfighter stamina, and reduces mission exposure.



A quick connect, powertool-like battery allows for on-the-fly swapping of batteries for extended operation, packload distribution, and improved mission planning.

POWERFUL

Able to lift over 600 lbs directly, the lightweight system improves force protection and reduces the operational footprint by replacing a 6-9 man haul team and complicated haul systems for CASEVAC missions.



To achieve a tactical advantage, perform material haul, or rescue casualties, military doctrine often requires the ascent of men and materiel over steep obstacles in mountainous, urban, and maritime environments. This is a highly technical and physically exhausting task that consumes the warfighter and impacts mission planning. To eliminate the burden of vertical obstacles, Atlas Devices developed the APA-5.

Building upon its theater-proven predecessor, the Atlas Powered Ascender is a rugged, battery operated ascender that easily integrates into current SOPs and COTS climbing equipment. Whether operating at maritime depth, in a desert dust storm, or 100' AGL in a helicopter, the Atlas Powered Ascender is a force multiplier that effortlessly reduces time and exposure during vertical operations.

LIGHTWEIGHT

Designed for the dismounted warfighter, the ascender weight is about the same as two 150' lengths of 7/16" static rope.

INTERCHANGEABLE BATTERY

APA-5 ACCESSORIES

WIRELESS REMOTE / WIRED REMOTE

The wireless remote control is an optional accessory that can operate the APA-5 from a distance. The remote is designed to mimic the user interface of the main ascender, including fully proportional ascent and descent control in both fast and slow modes. The remote communicates with a wireless receiver module that is integrated with the ascender as an add-on item. The wireless remote control expands the capability of the ascender especially in "hands off scenarios" such as hoisting into a helicopter, where it is necessary to have control of both the ascender and the incoming load at the same time. The wired version of the remote control is similar but is plugged directly into the ascender unit auxiliary remote port.

WIRELESS RECEIVER

The wireless receiver is an optional accessory that pairs with the wireless remote. The receiver module seamlessly integrates within the ascender system, creating a low profile, reliable unit with wireless operating capabilities. Just like the ascender, the wireless receiver is fully waterproof, rugged and performs in any environment.

SMALL DIAMETER ROPE DEVICE

The APA-5 ascender is able to operate a wide variety of rope diameters from 6.0-11.0 mm when the Multi-diameter Rope Capability option is selected. In addition to modifications to the rope interaction mechanism on the APA-5 unit, the Small Diameter Rope Device is included with the system to optimize operations with small diameter ropes (6.0 - 8.0 mm). This patented lightweight and compact device is a modular attachment that can be rapidly engaged with a bight of rope.

EDGE PROTECTION GUARD

The Edge Protection Guard is an optional accessory that safely directs load in applications where the ascender is used as a winch loaded against a ground plane. The Edge Protection Guard provides increased stability, traction and protects vital parts of the ascender system in these scenarios. Its unique design allows for a hot swap battery interchange while operating the system under load. When the guard is not in use, the modular guard can easily be disconnected with a quick release pin.

STANDARD DISTANCE / HIGH CAPACITY BATTERY (INTERCHANGEABLE)

The APA-5 features an interchangeable battery. The power supply can be replaced during operation, while under load, and while fully submerged. For operations that require additional time and a larger power supply, Atlas Devices offers a high capacity battery which offers 2x the ascending distance of the Standard Distance Battery in a package that is less than 2x the size and weight of the Standard Distance Battery.

ATLAS DEVICES TOUGHLINE

Atlas Devices' ToughLine is a static kernmantle rope developed specifically for the demands of powered ascent. Leveraging a Technora sheath and optimized weave construction, the Atlas Toughline is the ideal rope for use with Atlas Powered Ascenders and provides superior abrasion resistance, shape and prolonged life - especially with heavy loads. Although other kernmantle ropes can be used by the Atlas Powered Ascenders, the Toughlines have consistently outperformed other ropes in all environmental conditions ranging from iced, wet, sandy, dirty, and soiled environments without any degradation in performance. DO NOT use Atlas Powered Ascenders with twisted nylon, hemp "gold line," or other non-kernmantle ropes!

Atlas toughline (Static Kernmantle) rope overview			
Diameter (mm Ø)	MBS (lbf)	Weight (g/m) / (lb/100ft)	Atlas PN
10,5	10000	71,68 / 4.8	ATL-150-10.5
9	6500	54,6 / 3.6	ATL-150-9
8	4500	41,68 / 2.8	ATL-150-8
6,5	4500	29,51 / 1.4	ATL-150-6.5



ATLAS POWERED ASCENDER APA-4

HIGH SPEED CLIMBING

Atlas Devices' APA-4 is a multi-mission high speed single-person ascender based on Atlas's proven technology and adapted for use where speed and versatility are priorities. The APA-4 lifts up to 350 lbs directly, climbs at up to 3.5 ft/second, handles ropes from 6-11mm in diameter, operates at maritime depth, and has a hot-swappable battery. A manual brake release allows descent with no battery, and an integrated 2:1 attachment allows users to build mechanical advantage systems quickly and easily to lift loads up to 700 lbs (expert use only). Also as with all products in the Atlas Devices family, it is compatible with all APA-5 batteries and remotes.



Specifications	
Weight	15.6 lbs / 7.1 kg
Dimensions	11.4 x 6.5 x 5 in / 28.9x16.5x12.7 cm
Weight w /std. battery	22.9 lbs / 10.4 kg
Weight w / high cap. battery	28.1 lbs / 12.8 kg
Dimensions w / std. battery	13.2x5.1x11.7 in / 33.6 cm

Ascent distance per charge, standard battery, single user: 700 ft @ 250 lbs / 213 m @ 113 kg
 Ascent distance per charge, high capacity battery, single user: 1400 ft @ 250 lbs / 427 m @ 113 kg
 Ascent speed: Variable (high speed)
 Lift capacity: 350 lbs / 158 kg
 Rope diameters: 6.5 - 11 mm
 Submergence rating allows connect /disconnect at depth.
 Ergonomic design for interchange at during operation.
 Redundant mechanical battery interlock.
 Recharge battery upon descent.
 Compatible with APA-5 remotes.

ASCENDER COMPARISON



APA-5

- Two-person loads, rescue, aircraft hoisting, maritime boarding
- Lift capacity: 272 kg
- Submersion: 10-30m
- Weight: 6,7 kg
- Wireless Remote Control
- Standard Battery
- High Capacity Battery
- Rope: 6,5-11mm
- Charger
- Battery Edge Protection
- Travel Case



APA-4

- Single person high speed climbing, urban access, maritime boarding.
- Lift capacity: 158 kg
- Submersion: 10-20m
- Weight: 7 kg
- Wireless Remote Control
- Standard Battery
- High Capacity Battery
- Rope: 6,5-11mm
- Charger
- Battery Edge Protection
- Travel Case



APA-2

- Single person climbing, launch and ascend, urban access, maritime boarding.
- Lift capacity: 158 kg
- Submersion: 10-20m
- Weight: 4,9 kg
- Wireless Remote Control
- Low Profile Battery
- Rope: 6,5-9mm
- Charger
- Travel Case



THE COMPLETE SYSTEM



In the crucial work of building, maintaining and repairing live electrical transmission and distribution infrastructure, accessing work positions can be challenging, dangerous, and costly. Atlas Devices products and techniques help linemen and electricians complete jobs safer, faster, higher, and with twice the efficiency in a handheld portable solution. By adapting our field-proven military solutions toward the utility sector's unique energized requirements, we have given line crews powerful enhancements to their efficiency and safety. With our solutions, line crews have completed jobs up to 8 times faster, gained immediate on-site rescue capability with smaller teams, and get first man up in only minutes in true compliance with OSHA-required 100% attachment. An Atlas Devices Solution can build and promote a Return on Investment in as little as 1-2 jobs per system.



REBS Compact Launcher
BE000165

+



Atlas Ascender APA 5-U
BE000378

REBS®

MAGNETIC CLIMBING SYSTEM

The Magnetic Climbing System (MCS) consists of a pair of shoes and hand grips. The MCS is used for efficiently climbing ferromagnetic surfaces. The system can provide access to ships and structures where hook and climb is not possible, and can even be used by divers to board a ship from the sea.

Magnetic Climbing System (MCS)

An extremely powerful magnetic climbing system that easily supports the weight of one fully equipped operator. The system consists of a pair of lever-operated magnetic shoes and hand grips for climbing on ferromagnetic surfaces. It works equally well for urban and maritime climbing of steel structures, and can be used from a submerged approach or from boat to boat.

Safety Quick release

The system has a quick release function for rapidly exiting the magnetic shoes in case of an emergency.

The system is delivered in a robust custom made storage box with all the necessary accessories, but can also be delivered as separate items.



REBS Magnetic Climbing System		BE005737
Part name	Part no.	Pcs.
REBS Hand Unit Left	BE007574	1
REBS Hand Unit Right	BE007575	1
REBS Foot Unit Right	BE007576	1
REBS Foot Unit Left	BE007577	1
Handle Slings	BE357666	1
Storage Box	BE006687	1
Handle Plate	BE116593	1
Quick Release Pull Wire L 700	BE117649	2
Thigh sleeve	BE357673	2
Calf sleeve L Large	BE357672	1
Calf sleeve R large	BE357667	1



MAGNETIC CLIMBING SYSTEM USAGE PROCESS

1	2	3	4	5	6
PREPARE	GRAB	CONNECT	PLACE	RELEASE AND RISE	SCALE
Fasten the security line on the swiveling connector on both Magnetic Climbing Handgrips and secure the line to the climber harness.	Grab a hold of both handgrips. The side where the arm brace allows the arm to pass through should be on the outside.	Place the handgrip with the front wheel against the surface.	Carefully rotate the handgrip to fasten the magnet silently to the surface.	Rotate the handgrip backwards to release the magnet with the easy release lever.	Repeat steps 3 and 4 to scale up vertical metal surfaces.

1	2	3	4	5
PREPARE	PLACE	PLACE	RELEASE AND RISE	SCALE
Enter the Magnetic Climbing Shoe and fasten the binding.	Place the shoe with the front wheel against the surface.	Rotate the shoe carefully towards the surface to attach silently.	Rotating the shoe outwards releases the magnet with the easy release function.	Repeat steps 2 and 3 to scale up vertical metal surfaces.

1	2	3	4
PREPARE	PLACE FOOT	CLOSE	ADJUST
Open the step-in-binding to prepare the Magnetic Climbing Shoe for use.	Place foot inside the binding.	Close the clasp on the step-in-binding to prepare for adjusting.	Use the tightening clasps on the binding to adjust the binding properly. Once adjusted, you only need to use the backside clasp to fasten and loosen the binding.

MAGNETIC CLIMBING SYSTEM MAIN FEATURES

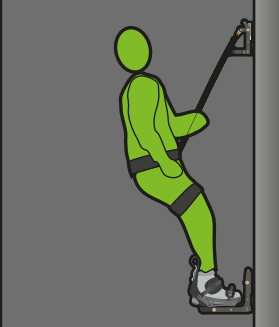

SECURITY LINE

Between the swiveling fasteners on the Systems Handgrips is a security line to which the user is connected. This line enables the user to release the hand grips and have both arms free.



EASY RELEASE

The easy release system enables the powerful magnets to be easily detached from the climbing surface.



HIGH FORCE

The Magnetic Climbing System uses extremely powerful magnets that attaches to metal surfaces with great force, and the system easily supports a fully equipped operator.



STEP IN BINDINGS

The system is connected to the user with easy to use and efficient step in bindings. Once adjusted you only need to use a single clasp to fasten or unfasten the Magnetic Climbing shoe.



WALL ROLLERS

The Magnetic Climbing System has plastic wheels so that the system can be placed and repositioned quiet and smoothly on the climbing surface.



SCUBA TUBE

The Scuba Tube provides an easy and efficient way of transporting equipment safely and dry under water.

It has two ports that can be used to route cables or wires through the lid, and that way keep electronics and batteries dry. It is available in different lengths to suit different transportation needs. A modular design lets you combine sections to your capacity needs. The Scuba Tube is rated for maximum 100 m depth.

The Scuba Tube is equipped with a vacuum valve for building up a vacuum inside the Scuba tube and to release the vacuum in order to easily remove the lid. Handling of the Scuba Tube is made easy by the large and accessible handle on the lid. In the other end is a fastening point for underwater towing. Use this point to tie in a rope or clip in a carabiner with a towing line. Opening and closing of the air tight lid is made simple with efficient cam lever dual action (force open / force close) handles.



SCUBA TUBE - MODULES AND DIMENSIONS

Configuration Template For Scuba Tube Systems

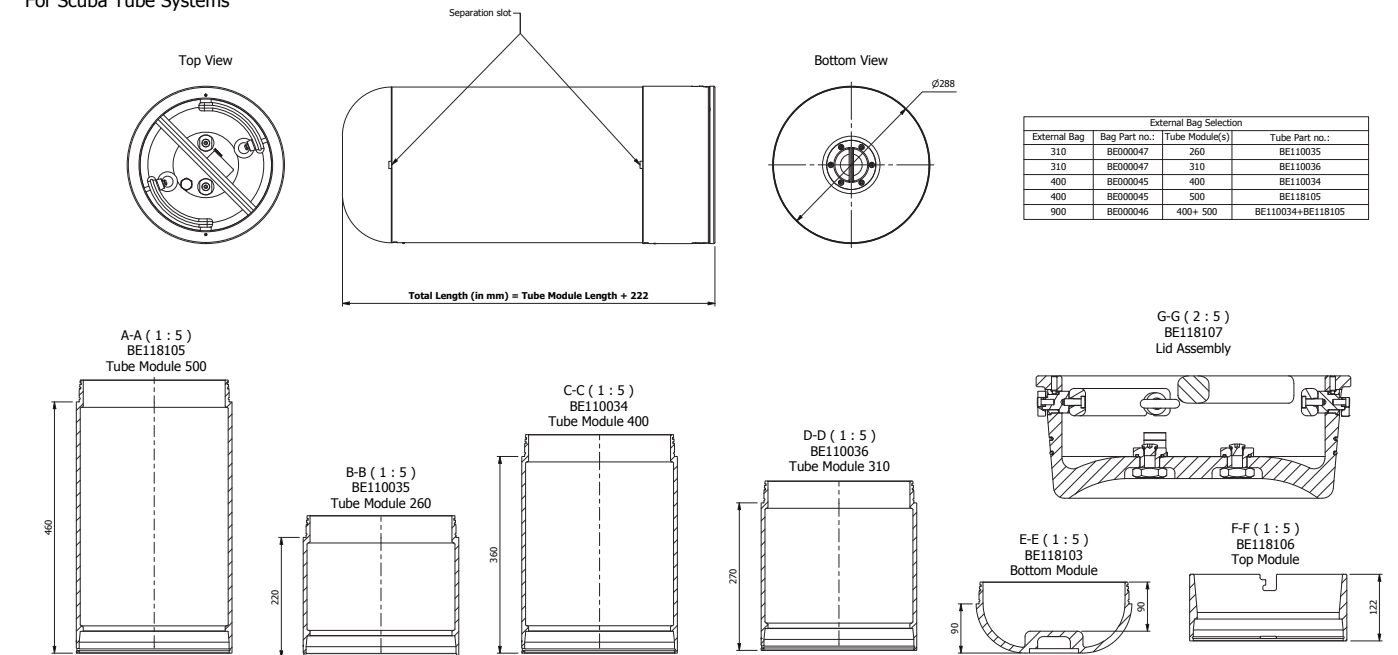

Scuba tube configuration examples*					
Type	Internal Volume (L)	Outer Length mm / in	Inner length mm / in	Weight kg / lbs	B.N.W.* Kg / lbs
500+500	57,7	1142 / 45"	940 / 37"	30,5 / 67.2	70,5 / 155.4
500+400	52,0	1042 / 41"	840 / 33"	28,9 / 63.7	64,0 / 141.1
500+310	46,8	952 / 37.5"	750 / 29.5"	27,4 / 60.4	58,1 / 128.1
500	31,2	682 / 26.9"	480 / 18.9"	22,2 / 48.9	40,2 / 88.6
400	28,3	582 / 22.9"	380 / 15.0"	20,5 / 45.2	33,6 / 74.1
310	23,1	492 / 19.4"	290 / 11.4"	19,1 / 42.1	27,7 / 61.1
260	20,2	442 / 17.4"	240 / 9.4"	18,2 / 40.1	24,5 / 54.0
Top + Base	4,7	222 / 8.7"	20 / 0.8"	13,9 / 30.6	9,8 / 21.6 (sinks)

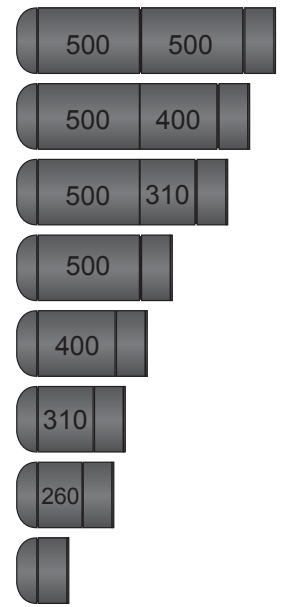

*Custom sizes or design available on request. Contact us for more information about special projects.

REBS®

TRANSOM ADAPTER

The Transom Adapter has been designed to enhance the capability of rapidly deployable Inflatable Boat Platforms. When coupled with a short shaft OBM, the adaptor allows the boat to be bundled and air dropped with the motor already fitted to the transom. To deploy, the motor can be indexed from parallel to perpendicular with the transom and then with the operation of a foot pedal, the OBM is then lowered into the water. All of which can be carried out by single operator without any tools. When coupled with the fast inflation system and inflatable floor, setup time and operator exertion is significantly reduced.

When underway, maintenance and OBM change out is also much safer because the power head (and COG) is inboard of the transom and the OBM can easily be slid out of the Adaptor after removal of a single Retaining Pin.

The design also offers flexibility as it can be fitted to multiple in-service inflatable boat models (currently fitted to Zodiac & Wing Inflatables) and can integrate a range of OBMs as well (currently run with Tohatsu & Raider OBMs). BDI design, manufacture and certify the items, the design can be adapted to meet user requirements and preferences. Transom Plates can also be provided for fitment of long shaft motors or twin OBM applications if required.

All components are CNC machined from 316 Stainless Steel and Marine Grade Aluminum so that the design is suited to the maritime environment and the system as a whole has been designed with ease of inspection and maintenance in mind

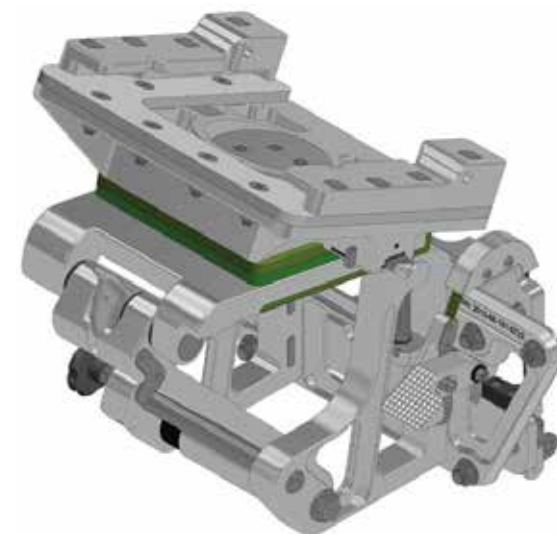

Specifications	
Part no.	BE000091
Material	AISI 316 / Aluminium alloy (marine grade)
Weight	20 kg / 44 lbs
Typical capacity	40 - 55 HP

REBS®

TRANSOM ADAPTER DETAILS



STOWED CONFIGURATION
Obm is locked above and parallel to transom.



RAISED CONFIGURATION
OBM is locked above and perpendicular to transom. OBM is retained by a single pin. Once removed, the OBM slides out of the bracket for quick and safe changeout at sea.



UNDERWAY CONFIGURATION
OBM is locked in the operational/down position. The OBMs full range of trim, steering & shallow water drive settings still available.

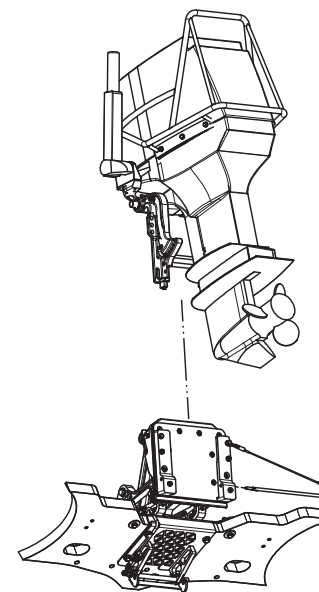

REMOVAL OF OBM
The OBM is easily removed by disengaging the retainer pin. The motor can be safely removed whilst on the water because the motor COG is inboard of the transom during the entire procedure.

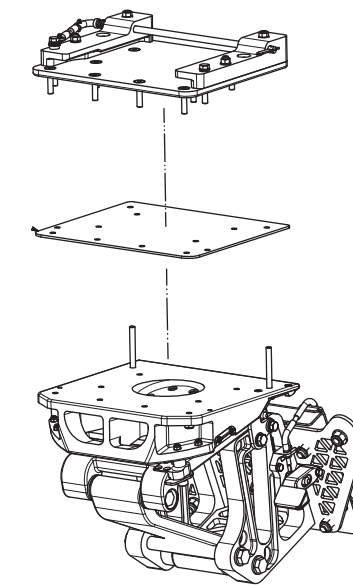

UNDERWATER CACHING
The transom adapter assembly is designed to integrate with underwater engine bags used in underwater caching.

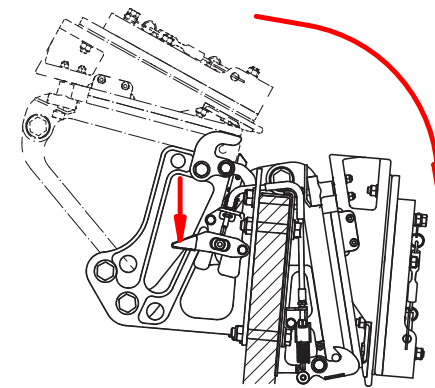

SIMPLE OPERATION
A single foot pedal is used to lower the OBM into the underway position.

REBS®

MAGNET ASSEMBLY KIT

The Magnet System - Diving Kit (BE000301) is a module-based system with various components, which can easily be configured for your needs. The kit is built up for use in special operations in the marine environment, especially for fastening on ferritic steel ship hulls.

The kit contains magnets with a wide range of different magnetic force, from a range of 7 kg and up to 520 kg. The holding force of the magnets is theoretical and will be varying with different surfaces, such as paint thickness, rust or thickness of the steel.

SQUEEZE RELEASE MAGNET

The Squeeze Release Magnet is a magnetic anchoring point, used to fasten to surfaces made of ferritic steel.

The handle of the releaser provides an easy and silent way to attach and detach the magnet from the contact surface.

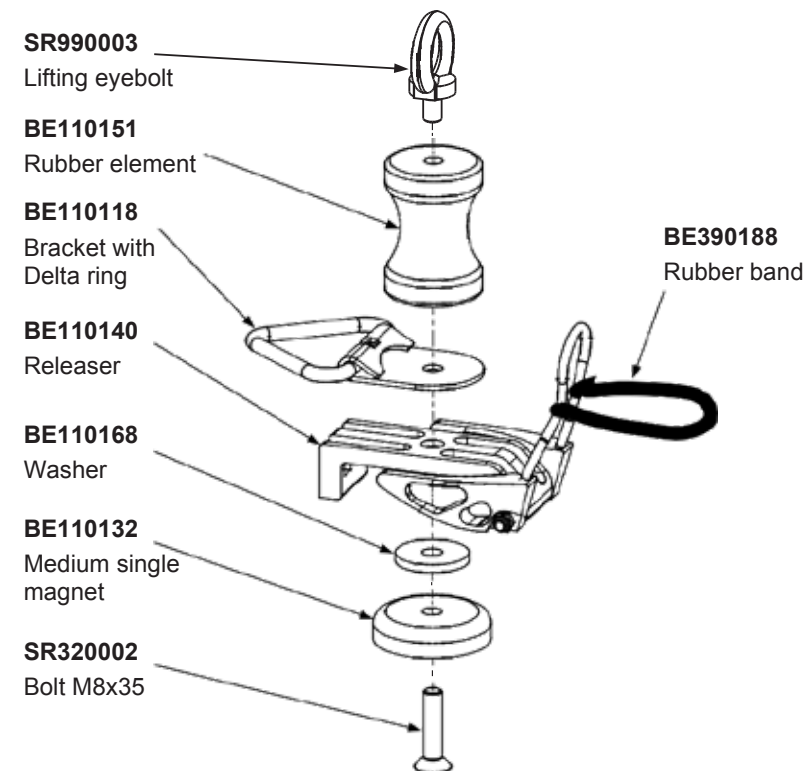

BE000427 configuration



TWIST RELEASE MAGNET



The Twist Release Magnet (BE000158) is a magnetic anchoring point. Twisting the handle provides silent and easy attachment and release to surface made of ferritic steel.

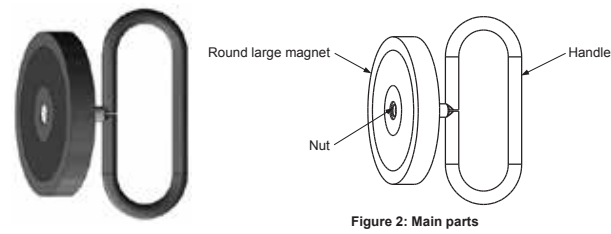

Attaching the magnet to the surface:

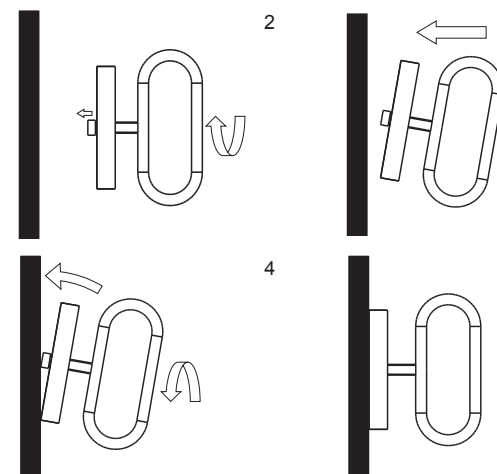

REBS®

BAND MAGNET

The Band Magnet is a versatile magnetic anchor system. The system offers many different configurations for attaching anchoring structures for different objects to surfaces made of ferritic steel.

Selections of configurations:

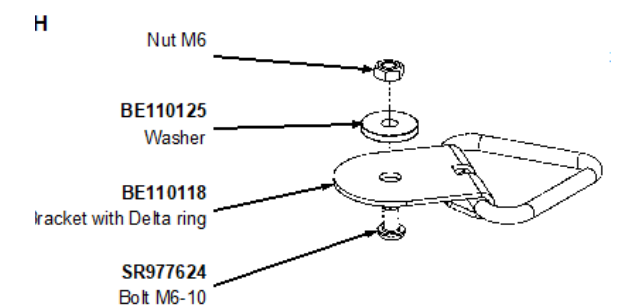
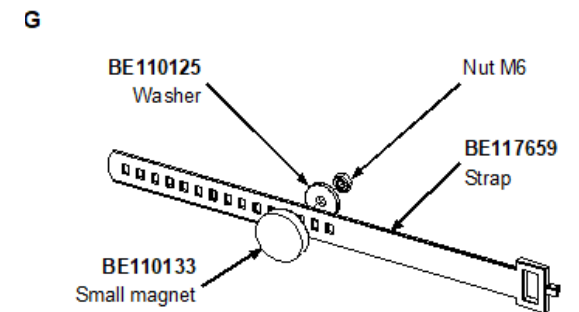
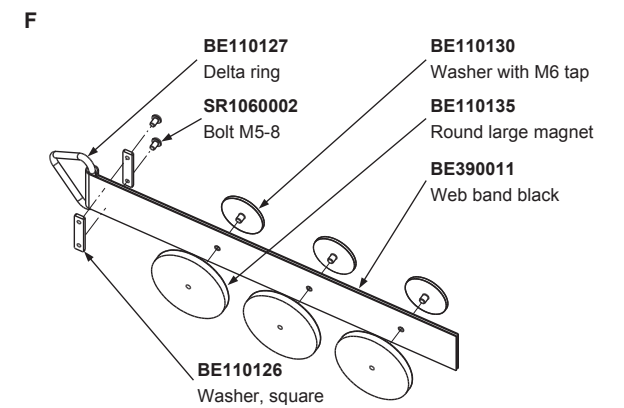
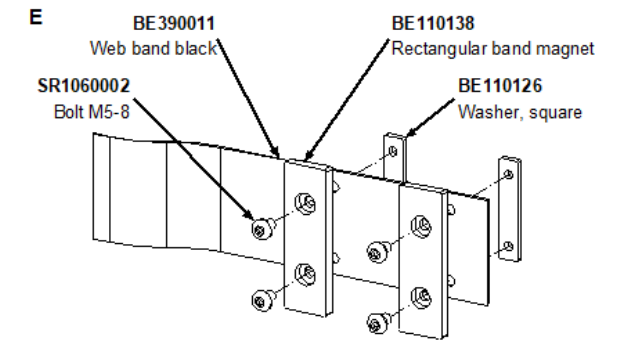
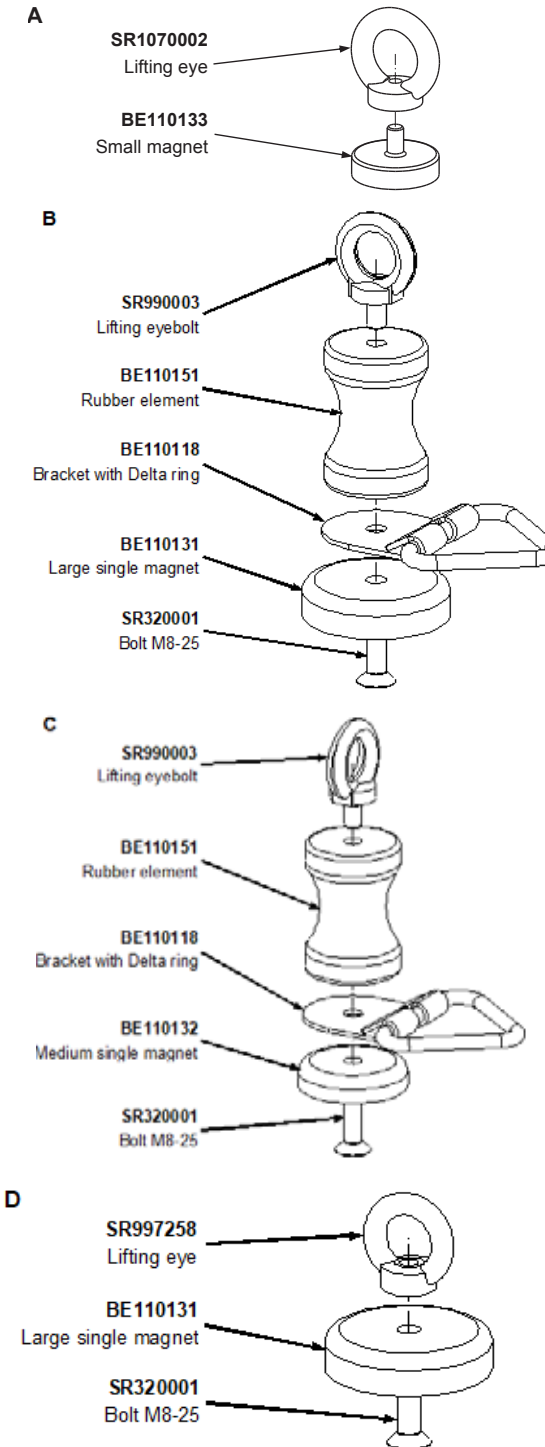

REBS®

MOORING MAGNET



The Mooring Magnet (BE000157) is a magnetic anchoring point with a maximum adhesive force of 520 kg. The unit is designed as a quick mooring point to the boat, removing the need for throttling with the motor to adjust the position of the boat. This makes the operation easier and more quiet in areas with current in the water or a moving object. The unit has a handle to attach and detach.

The kit contains magnets with a wide range of different magnetic force, from a range of 7 kg and up to 520 kg. The holding force of the magnets is theoretical and will be varying with different surfaces, such as paint thickness, rust or thickness of the steel.

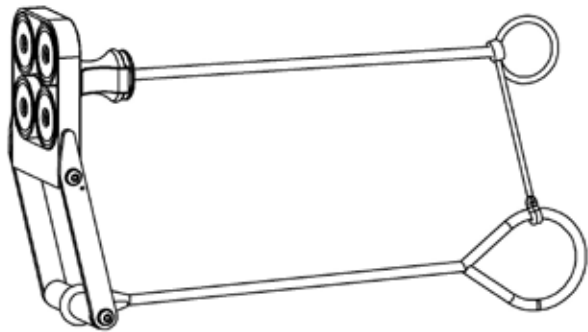

Specifications	
Part no.	BE000157
MBL Straight pull	520 kg*
MBL 740 angle pull	130 kg
Weight	2,6 kg

* Theoretical strength

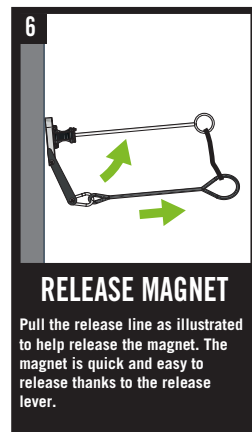
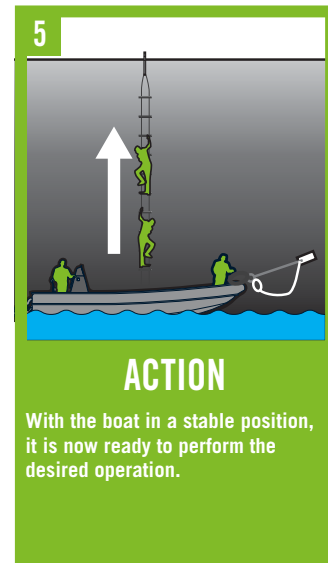
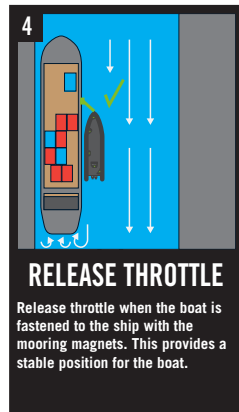
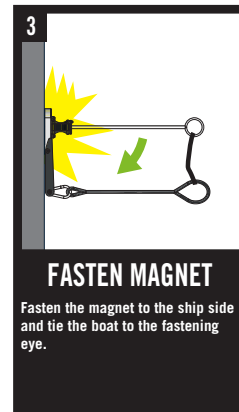
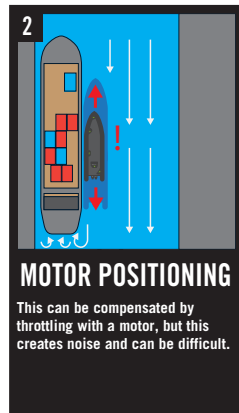
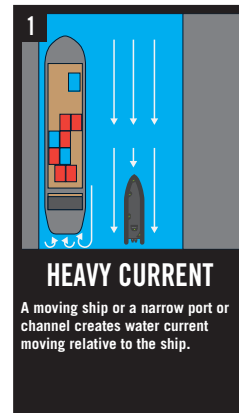

REBS®

ROPE CLIMBER

The REBS Rope Climber is a lightweight, compact and robust tool for efficient single rope ascension. It features large collapsible anti-slip surfaced foot supports which makes it both compact in size and efficient in use.

MAIN FEATURES

A collapsible rope climber that enables rapid deployment and rope fastening. Deployment is permitted by an integrated rubber cord release, making it quick and easy to use. It is also designed to allow one-handed fastening if required.

The handle is equipped with a mechanical thumb lever for quick and effective engagement/disengagement on the middle of the rope. Chrome-plated steel cam allows continuous ascent, even on wet ropes.

The anti-slip foot rests automatically adjust themselves to the user by spring-loaded upper arms which clamps onto the boots. Its large knurled surface allows the user to operate while using boots and/or fins.

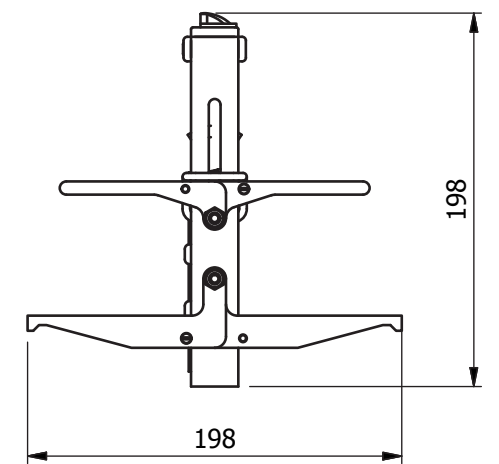
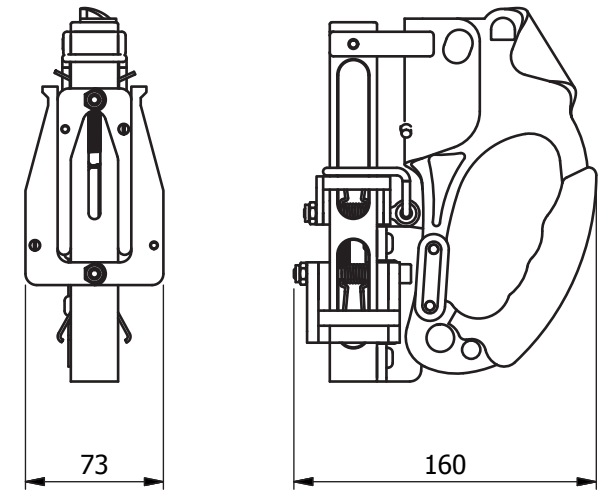

Specifications	
Part no.	BE004710
Material	Aluminium alloy
Finish	Matte black
Weight	0,7 kg / 1.54 lbs

K9 TACTICAL INSERTION DEVICE

The K9 Tactical Insertion Device (K-9TID) is a special device for use where the dog are a central capacity, like circumstances of terror, war, national crisis or under training of these situations.

K-9TID is a more secure and safer way to carry the dog under tactically very demanding situations for a strictly limited period.

The system is especially effective in high speed RIBs at sea; Creating an environment where the dog is kept safe laying down when the boat slams through the waves. The dog is no longer a limiting factor onboard the RIB and this improves the speed the boat can operate in considerably.

If the conditions permit the lid can be partly opened so the dog may look out. It's also a porthole with light to look in and out. To secure the dog inside the cage it can be fasten with fast loose end straps forward and backward.

The K-9TID is designed for the working dog. All internal walls including floor and lid, are insulated and covered with a "no gnaw- and scratchable" surface.

The ventilation is maintained through a system of air inlets and an electric fan keeps the dog cool under warm conditions. A heating system is integrated for use under cold environment.

Externally the K-9TID is designed for rough treatment, the system is designed to be attached to the vehicle, and also designed to be lifted. The system is also superb for use on other vehicles such as ATVs and snowmobiles.

The K-9TID can support the weight of 2 persons on the top of the lid. It has two set of wheels that makes it easy to move like a trolley. The device has handles and tie downs that are built-in. The bottom of the cage has six integrated attach points.

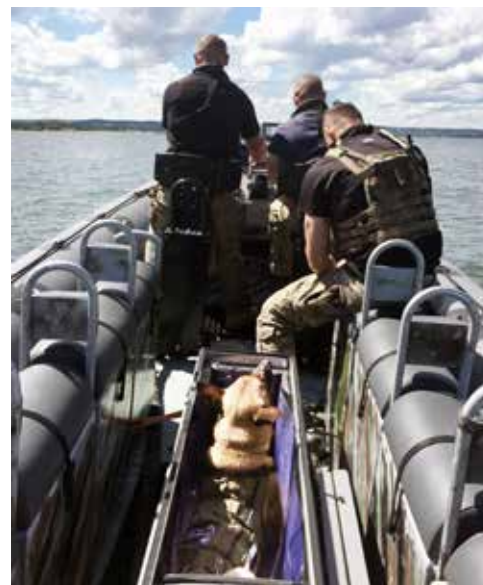

Specifications	
Part no.	BE000219
Dim	1200x400x450 lbh
Weight	25 kg
Material	Aluminium

Helix Operations provide a complete capability for vertical access and rescue in mountain, maritime and urban environments.

They are based in the mountains of North Wales and have a heritage of almost 40 years supplying tactical climbing solutions to end users. Over that time, they have worked with and become a main supplier of tactical climbing equipment to the UK MOD and have provided equipment and systems to many other nations.

Helix Operations provides access solutions worldwide for security, defence and rescue operations. They provide equipment, systems and training to enable operators to work with speed, ease, and safety when accessing objectives across a wide range of environments; mountain, urban or maritime.

	<table border="1"> <thead> <tr> <th colspan="2">Benchmade 8 Safety Cutter</th> </tr> </thead> <tbody> <tr> <td>Blade Steel</td> <td>440C</td> </tr> <tr> <td>Blade/Finish</td> <td>Coated</td> </tr> <tr> <td>Part no.</td> <td>BE390893</td> </tr> <tr> <td>Use</td> <td>Tactical/Rescue</td> </tr> </tbody> </table>	Benchmade 8 Safety Cutter		Blade Steel	440C	Blade/Finish	Coated	Part no.	BE390893	Use	Tactical/Rescue		<table border="1"> <thead> <tr> <th colspan="2">DMM Pivot</th> </tr> </thead> <tbody> <tr> <td>Colour</td> <td>Matt Grey</td> </tr> <tr> <td>Weight</td> <td>72/145 g</td> </tr> <tr> <td>Part no.</td> <td>BE390887</td> </tr> <tr> <td>Compatible with</td> <td>8,7-11 single mm ropes / 7,3-9,2 twin ropes</td> </tr> </tbody> </table>	DMM Pivot		Colour	Matt Grey	Weight	72/145 g	Part no.	BE390887	Compatible with	8,7-11 single mm ropes / 7,3-9,2 twin ropes
Benchmade 8 Safety Cutter																							
Blade Steel	440C																						
Blade/Finish	Coated																						
Part no.	BE390893																						
Use	Tactical/Rescue																						
DMM Pivot																							
Colour	Matt Grey																						
Weight	72/145 g																						
Part no.	BE390887																						
Compatible with	8,7-11 single mm ropes / 7,3-9,2 twin ropes																						
	<table border="1"> <thead> <tr> <th colspan="2">Petzl ASAP</th> </tr> </thead> <tbody> <tr> <td>Colour</td> <td>Orange</td> </tr> <tr> <td>Weight</td> <td>295 g</td> </tr> <tr> <td>Part no.</td> <td>BE390894</td> </tr> </tbody> </table>	Petzl ASAP		Colour	Orange	Weight	295 g	Part no.	BE390894		<table border="1"> <thead> <tr> <th colspan="2">Petzl Pirana</th> </tr> </thead> <tbody> <tr> <td>Colour</td> <td>Black</td> </tr> <tr> <td>Weight</td> <td>90 g</td> </tr> <tr> <td>Part no.</td> <td>BE390888</td> </tr> <tr> <td>Compatible with</td> <td>Single ropes 8-13mm</td> </tr> </tbody> </table>	Petzl Pirana		Colour	Black	Weight	90 g	Part no.	BE390888	Compatible with	Single ropes 8-13mm		
Petzl ASAP																							
Colour	Orange																						
Weight	295 g																						
Part no.	BE390894																						
Petzl Pirana																							
Colour	Black																						
Weight	90 g																						
Part no.	BE390888																						
Compatible with	Single ropes 8-13mm																						
	<table border="1"> <thead> <tr> <th colspan="2">Petzl ASAP'SORBBER</th> </tr> </thead> <tbody> <tr> <td>Colour</td> <td>Black/Yellow</td> </tr> <tr> <td>Weight</td> <td>125 g</td> </tr> <tr> <td>Part no.</td> <td>BE390895</td> </tr> <tr> <td>Lenght</td> <td>20 cm</td> </tr> </tbody> </table>	Petzl ASAP'SORBBER		Colour	Black/Yellow	Weight	125 g	Part no.	BE390895	Lenght	20 cm		<table border="1"> <thead> <tr> <th colspan="2">Phantom Safe Carabiner</th> </tr> </thead> <tbody> <tr> <td>Colour</td> <td>Matt Grey</td> </tr> <tr> <td>Weight</td> <td>42 g</td> </tr> <tr> <td>Part no.</td> <td>BE390889</td> </tr> <tr> <td>kN</td> <td>24/9/9</td> </tr> </tbody> </table>	Phantom Safe Carabiner		Colour	Matt Grey	Weight	42 g	Part no.	BE390889	kN	24/9/9
Petzl ASAP'SORBBER																							
Colour	Black/Yellow																						
Weight	125 g																						
Part no.	BE390895																						
Lenght	20 cm																						
Phantom Safe Carabiner																							
Colour	Matt Grey																						
Weight	42 g																						
Part no.	BE390889																						
kN	24/9/9																						
	<table border="1"> <thead> <tr> <th colspan="2">K-Pro Rope Protector</th> </tr> </thead> <tbody> <tr> <td>Colour</td> <td>Blue/Red,Black/Olive</td> </tr> <tr> <td>Lenght</td> <td>50-80 cm</td> </tr> <tr> <td>Part no.</td> <td>BE390896</td> </tr> </tbody> </table>	K-Pro Rope Protector		Colour	Blue/Red,Black/Olive	Lenght	50-80 cm	Part no.	BE390896		<table border="1"> <thead> <tr> <th colspan="2">Belay Master 2</th> </tr> </thead> <tbody> <tr> <td>Colour</td> <td>Matt Grey</td> </tr> <tr> <td>Weight</td> <td>93g</td> </tr> <tr> <td>Part no.</td> <td>BE390890</td> </tr> <tr> <td>kN</td> <td>25/10/8</td> </tr> </tbody> </table>	Belay Master 2		Colour	Matt Grey	Weight	93g	Part no.	BE390890	kN	25/10/8		
K-Pro Rope Protector																							
Colour	Blue/Red,Black/Olive																						
Lenght	50-80 cm																						
Part no.	BE390896																						
Belay Master 2																							
Colour	Matt Grey																						
Weight	93g																						
Part no.	BE390890																						
kN	25/10/8																						
	<table border="1"> <thead> <tr> <th colspan="2">Petzl RIG</th> </tr> </thead> <tbody> <tr> <td>Colour</td> <td>Black / Yellow</td> </tr> <tr> <td>Weight</td> <td>400 g</td> </tr> <tr> <td>Part no.</td> <td>BE390885</td> </tr> <tr> <td>MBL</td> <td>200 kg</td> </tr> </tbody> </table>	Petzl RIG		Colour	Black / Yellow	Weight	400 g	Part no.	BE390885	MBL	200 kg		<table border="1"> <thead> <tr> <th colspan="2">Chimera</th> </tr> </thead> <tbody> <tr> <td>Colour</td> <td>Matt Grey/Black</td> </tr> <tr> <td>Weight</td> <td>30 g</td> </tr> <tr> <td>Part no.</td> <td>BE390891</td> </tr> <tr> <td>kN</td> <td>23/7/9</td> </tr> </tbody> </table>	Chimera		Colour	Matt Grey/Black	Weight	30 g	Part no.	BE390891	kN	23/7/9
Petzl RIG																							
Colour	Black / Yellow																						
Weight	400 g																						
Part no.	BE390885																						
MBL	200 kg																						
Chimera																							
Colour	Matt Grey/Black																						
Weight	30 g																						
Part no.	BE390891																						
kN	23/7/9																						
	<table border="1"> <thead> <tr> <th colspan="2">DMM Anka</th> </tr> </thead> <tbody> <tr> <td>Colour</td> <td>Matt Grey / Black</td> </tr> <tr> <td>Weight</td> <td>169 g</td> </tr> <tr> <td>Part no.</td> <td>BE390886</td> </tr> </tbody> </table>	DMM Anka		Colour	Matt Grey / Black	Weight	169 g	Part no.	BE390886		<table border="1"> <thead> <tr> <th colspan="2">The Revolver</th> </tr> </thead> <tbody> <tr> <td>Colour</td> <td>Matt Grey/Black</td> </tr> <tr> <td>Weight</td> <td>51 g</td> </tr> <tr> <td>Part no.</td> <td>BE390892</td> </tr> <tr> <td>kN</td> <td>24/7/9</td> </tr> </tbody> </table>	The Revolver		Colour	Matt Grey/Black	Weight	51 g	Part no.	BE390892	kN	24/7/9		
DMM Anka																							
Colour	Matt Grey / Black																						
Weight	169 g																						
Part no.	BE390886																						
The Revolver																							
Colour	Matt Grey/Black																						
Weight	51 g																						
Part no.	BE390892																						
kN	24/7/9																						



Aztek Full Block System	
Colour	Black/Yellow
Part no.	BE390897
Max rope diameter	8mm



Pitcher Rope Bag 26L	
Colour	Black/Coyote
Weight	470 g
Part no.	BE390898



Petzl Cordex Plus Gloves	
Colour	Black/Beige
Size	XS-XL
Part no.	BE390899
Material	Leather



Slings- Dynatec	
Lenght	30-400 cm
Width	8mm
Part no.	BE390900
kN	22



Nava Special Warfare Harness	
Colour	Blackk, Multicam, Coyote Brown
Size	S-XL
Part no.	BE390906
kN	15



R3 Waist Harness	
Colour	Black, Khaki Green, Coyote Brown
Weight	475-510 g
Part no.	BE390908
Waist	68-132 cm



RAID Modular Harness System	
Colour	Black/Multicam
Size	S-L/M-XL
Part no.	BE390907
User weight	150 kg

HELO SPECIAL INSERTION AND EXTRACTION



The unique construction of the Marlow Fast Rope allows for comfortable control throughout the descent and makes it easier to slow down and brake. The suppleness of the construction means that the rope is not hard on the hands and less force is required that with other ropes. Oil and general spillages do not affect speed or control during descent as the Marlow Fast Rope will absorb liquids. Available in standard 40mm nominal diameter and thinner 32mm nominal diameter version.

Each Marlow F.R.I.E.S can carry 6 fully equipped personnel with it's loop and lanyard system and can also be used as a regular Fast Rope.



Fast rope Descender
Marlow have now launched the Fast Rope Rack (FRR) to be used in conjunction with 40mm fast rope and to aid the rapid insertion of units. It is quick and easy to install.



Each Fast rope is delivered in a Storage Bag.

BASIC RAPPEL KIT



BASIC OPERATOR KIT



REBS®

REBS TRAINING

REBS Training Modules:

Basic 1-4 days)

The REBS Tailored Basic Maritime Interdiction Course (1-4 days) is designed to get the teams quickly up to speed on the tactical implementation of high-end boarding equipment.

Advanced (5 days – 10 weeks modular training course)

The REBS Tailored Advanced Training Course is a complete modular Maritime Interdiction or Counter Terrorism interdictions training course with all assets including HeloOps and Special Operations Craft.

All REBS courses are designed and conducted by world leading specialist in counter terrorism and maritime interdiction. Contact us for information and quote.



REBS SERVICE AND RECERTIFICATION

To maintain climbing safety and safety with regards to high pressure products, such as the launcher, we recommend that all products is subject to service and recertification every 2 year. Such recertification will also renew the product warranty.

A recertifications includes:

- Changing all predefined items with limited lifetime
- Change any reduced items.
- Test the system for hidden defects
- Refurbish to have almost new appearance, technical and visual

The work can be done:

- In the REBS workshop
- At customer site by REBS trained personnel.

Contact service@rebs.no if you have questions regarding service or you want to start a service program.



REBS®



**RE[®]
BS**

**Reducing
Operational
Risk**

-

**Maximizing
Operational
Performance**

HENRIKSEN

H. Henriksen AS

Træleborgveien 15
3112 Tønsberg

Phone: +47 333 78 400

Mail: rebs@hhenriksen.com

www.hhenriksen.com

M000297 Rev.: 22-1