

REBS®



VALUES

HIGH STRENGTH

HIGH SPEED

LIGHT WEIGHT

LOW EXPOSURE

REBS

TABLE OF CONTENTS

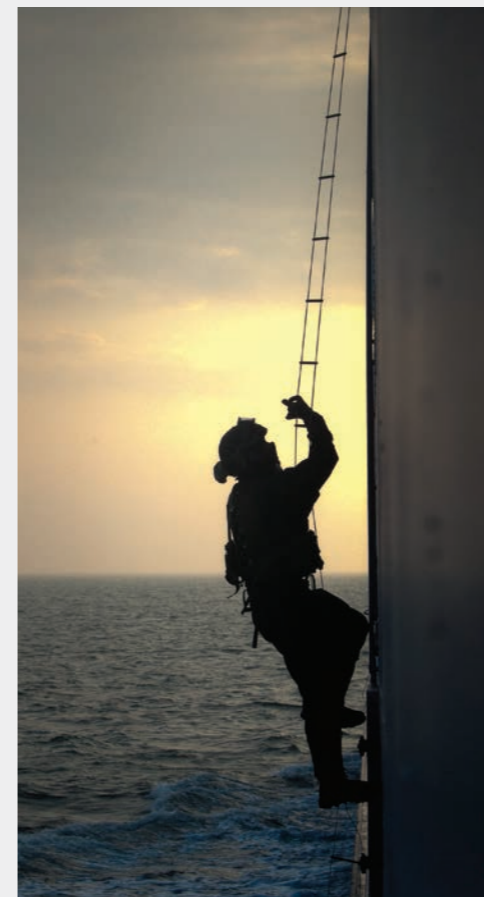

Introduction	5
Ladders	6
Ultralight Pole Ladder (UPL)	9
Carbon Multi Ladder (CML)	11
Full range of ladders	13
Hooks	14
Poles	16
SKYPOLE	19
Launchers	21
Ascenders	23
Magnetic climbing system (MCS)	25
Scuba tube	26
Tactical Access Ramp (T.A.R.)	29
Versatile product range	30
Reach chart	32

The users of REBS products aim to minimize exposure. We strive to make our products safer, stronger, lighter and faster than any other products in order to maximize the operational performance of our users.



*Reducing Operational Risk –
Maximizing Operational Performance*

INTRODUCTION

REBS

The Rapid Entering and Boarding Systems (REBS[®]) segment was established at Henriksen in 2003 as a response to a initiative from the Norwegian Defense. They sought products that could increase the effectiveness and safety of boarding operations, especially at sea. Boarding is a high risk operation and the users wanted equipment that was safe and thoroughly tested.

With time REBS has evolved into a result of a multinational cooperation, where input from users in different countries has resulted in product improvements and a reduced operational risk. This development has resulted in several state of the art boarding products.

Boarding operations poses many challenges and the equipment suffers from rough use in demanding environments. The products therefore have to be as lightweight as possible while still being strong and durable. To meet these challenges, we utilize high performance materials like carbon fiber and titanium. We develop and manufacture several products in-house as well as cooperate with other manufacturers of unique high-quality boarding products.

LIGHTWEIGHT, STRONG WITH MULTIPLE USE

LADDERS

We offer a diverse suite of ladders optimized for urban, maritime, and rugged terrain use. We have several different categories.

Ladders offered by REBS can also be used for bridging short and medium distances, and may also double as litters or stretchers for casualty evacuation.

REBS FOCUS ON COMPLETE FLEXIBLE SYSTEMS

ROPE LADDERS:

- Wire ladder
- Rope ladder
- Ladder reel
- Web ladder
- FIFI Ladder Hook

RIGID LADDERS:

- Tactical ladder
- Ultralight Pole Ladder
- Carbon Multi Ladder
- Pool ladder
- Atlas LTL-28
- Atlas ATL



ULTRALIGHT POLE LADDER (UPL)

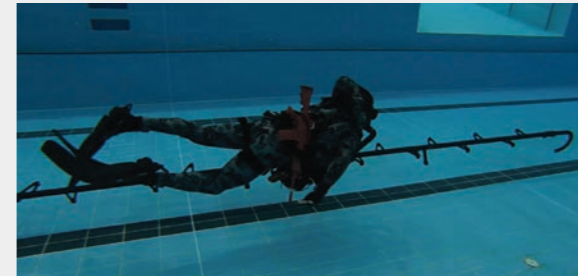

The REBS Ultralight Pole Ladder (UPL) is a light weight rigid section ladder that is excellent for both urban and marine boarding and climbing.

The modular design makes it easy to assemble the required amount of sections to make up the right length for the task at hand, because of our unique design with quick connectors.

Learn more: rebs.no



CARBON MULTI LADDER (CML)

The Carbon Multi Ladder is a multi function ladder system comprised of carbon fiber ladder sections. The innovative, lightweight, strong and smooth design is derived from the same advanced molding techniques also used to fabricate modern bicycle frames and components.

As a result of the state-of-the-art fabrication process, the ladder design optimizes the carbon fiber properties into a very strong monocoque frame. The Carbon Multi Ladder system packs into a low-volume package that is easily carried on a backpack or with the custom CML Backpack.





Rope Ladders



Web Ladder



Wire Ladders

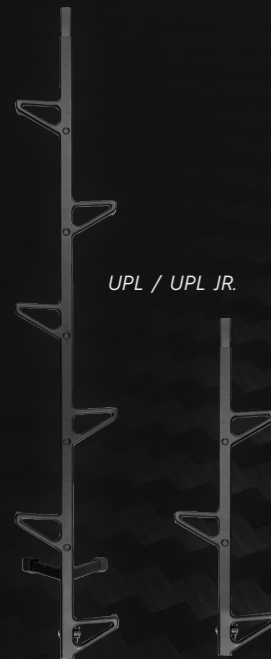

UPL / UPL JR.

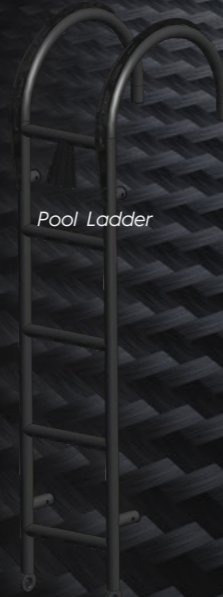

Pool Ladder



Tactical Ladder



CML Assault Ladder

FULL RANGE OF LADDERS

REBS offer a wide range of ladders for maritime and urban climbing.

The ladders can be used in diving as well as climb buildings or ships. The ladders are rigid and light weight. REBS Wire Ladder may also be used as an extension to a rigid ladder for better reach and flexibility.

Pool Ladder

CML (Carbon Multi Ladder)

UPL / UPL JR. (Ultralight Pole Ladder)

Tactical Ladder

CML Assault Ladder

Atlas Tactical Ladder

Atlas Pilot LAL-18

Wire Ladder

Wide Wire Ladder

Rope Ladder

Web Ladder

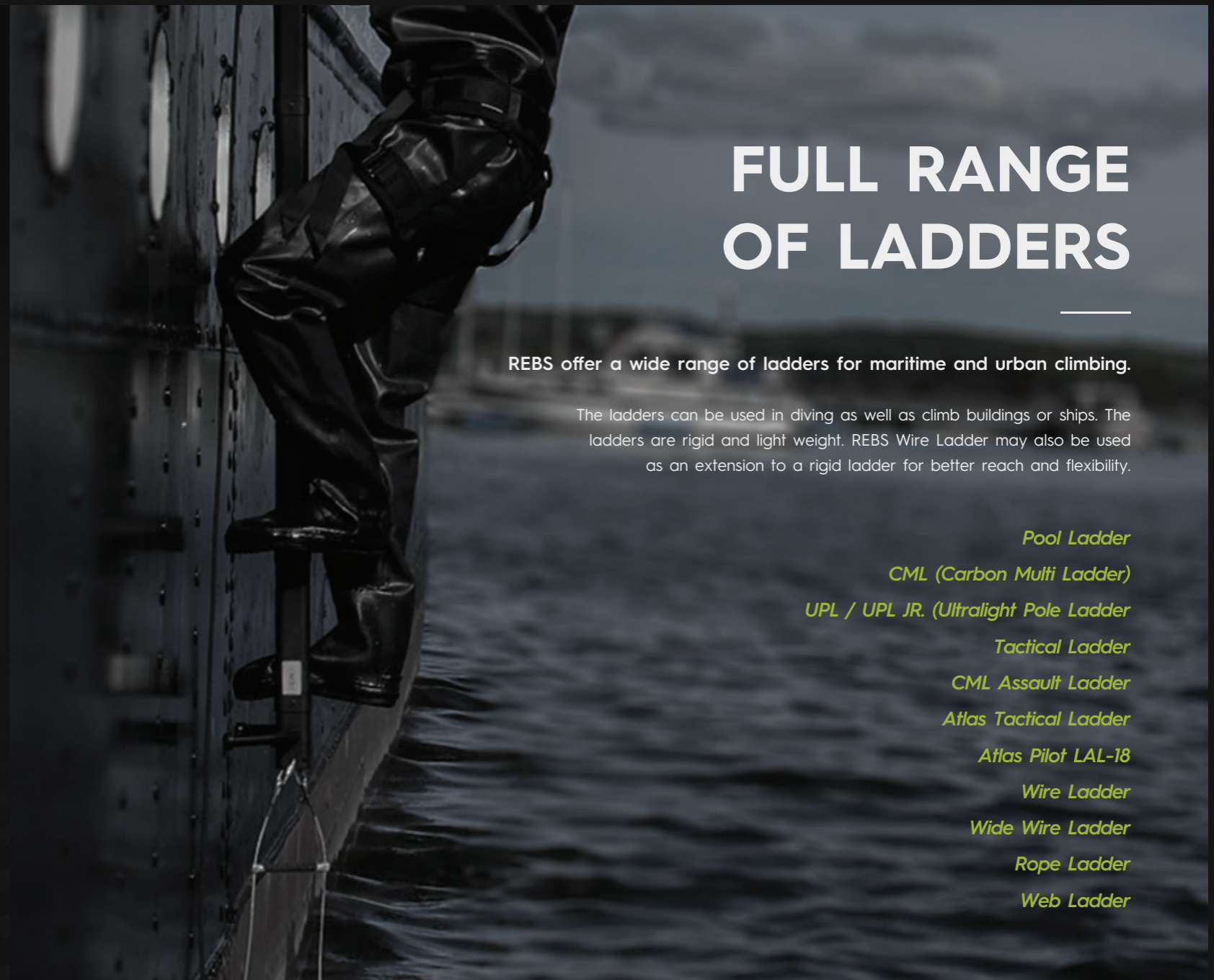

HOOKS

REBS Hooks are available in both single and dual configurations, and are delivered in several sizes between 2,5" and 10" to accommodate a large range of different boarding and climbing operations and fixture points.

We offer hooks in a variety of sizes, capacities and functions. Common for them all is a high capacity / weight ratio.

Learn more: rebs.no



REBS Hook
5" Titanium

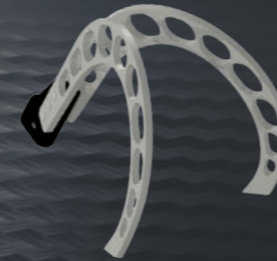

REBS Hook
6" Dual Titanium



REBS Hook 2,5"
with Rolatube Connector



REBS Hook
10" Tactical



REBS Hook
7" Tactical



REBS Maxgrip hook
with Tactical Connector



REBS Hook Dual
6,8" Tactical



REBS Hook
7" Titanium



REBS Hook
13" Tactical (for Skypole)



REBS Hook
9,5" Carbon Fiber



REBS Urban Hook with
Carabiner Mount



High strength steel tips and teeth give optimal grip to any surface

POLES

REBS Pneumatic Poles in connection with REBS compatible hooks and wire ladders makes boarding large maritime constructions like oil platforms or tanker ships quick and safe.

One of REBS biggest focus is development of the Pneumatic Poles. Our product ranges is from bistable composite material to roll out to powered extension poles.

The manual telescopic pole is delivered in different sizes and the Wind-up pole with winch and a belt system to extend it.

Compact, fast, strong and designed for use on both land and at sea

Telescopic Pole, 2,8-15m.

Rolatube, 3-5m.

Wind-up, 15m.

Giraffe, 10-15m.

Skypole, 15-20m



REBS SKYPOLE

The REBS SkyPole is a pneumatic powered extending and retracting pole for boarding and entering operations.

The REBS Skypole is easy to control and operate. Featuring precision trigger style control's mounted to the collapsible handle bars. Allowing the operator to precisely, and quickly reach the desired height. RBES Skypole is available in two different lengths, 15 and 20m reach. When retracted they measure 4,7 and 5,2 m respectively.

The rotating handle bar is quick to deploy or collapse into transportation-position in a matter of seconds. The Skypole baseplates are available in multiple sizes to allow for mounting to nearly any location, such as the deck of a RIB.

Learn more: rebs.no

A close-up photograph of the REBS Skypole handle bar. The handle bar is black with a silver REBS logo. It is mounted to a vertical pole. The background is dark with a pattern of small, light-colored dots.

*Powered with pressurized air,
which facilitates low noise operation
and enables easy reloading from
ordinary diving bottles.*

LAUNCHERS

Our Launchers uses compressed air to launch a grappling hook projectile great distances. We provide complete launcher packages, that includes all necessary equipment in a custom made storage and transportation box.

Launch the grapnel hook with titanium spring loaded arms for the highest reach or combine with a trailing rope ladder for a more effective operation.

REBS LAUNCHER

The REBS® Launcher enables users to access high-up entry points by launch a grapnel hook on to a permanent fixture and then ascending ropes fixed from that point. The Launcher is perfect for entering buildings, bridges, ships, platforms or cliffs as well as crossing ravines or rivers, both for military and rescue scenarios.

REBS COMPACT LAUNCHER

The Compact Launcher is a smaller version of the larger REBS Launcher, and has been developed for more versatile use than the big brother. Whereas the REBS Launcher is designed to be the ultimate boarding tool with unmatched performance, the Compact Launcher is designed to be a light weight, compact in size line thrower for many different applications.



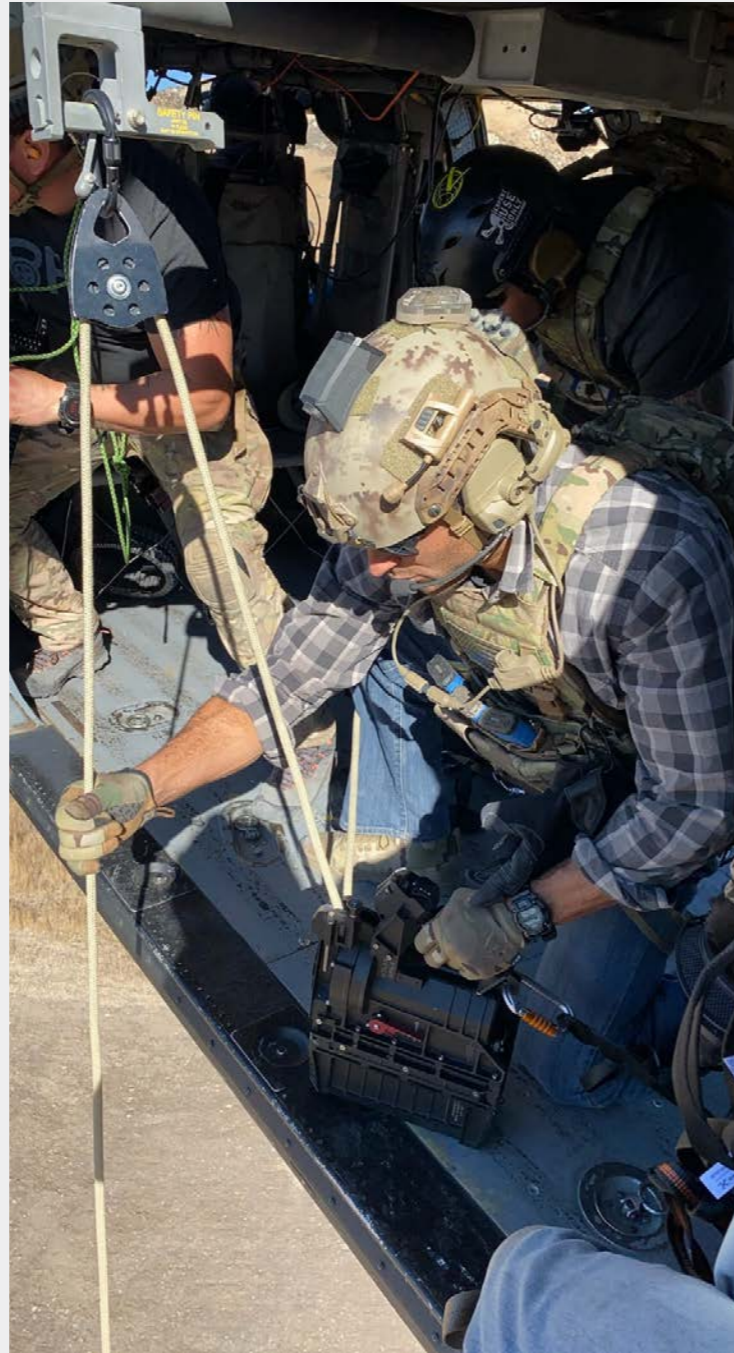
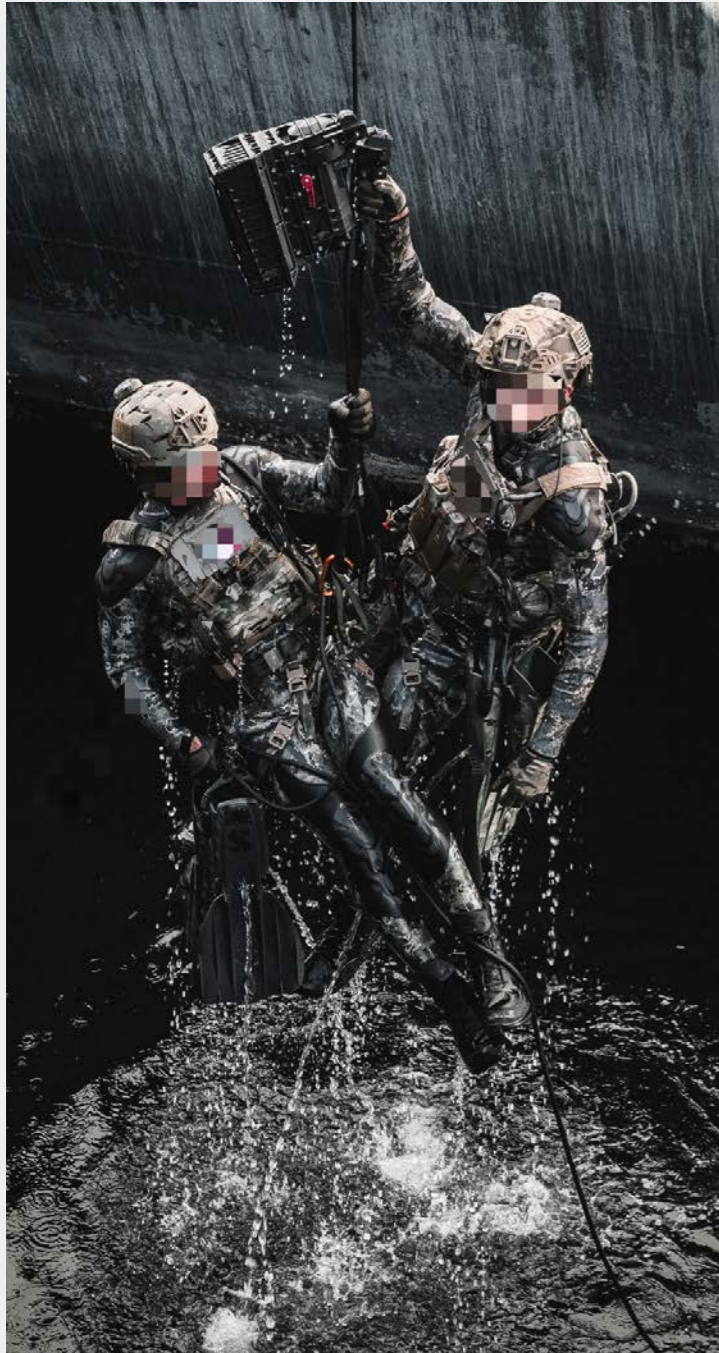

ASCENDERS

One of Atlas Devices' ascenders, APA-5, is a multi-mission device that hauls heavy personnel loads, extends stamina, and reduces mission exposure.

It is a rugged, battery operated ascender that integrates into current SOPs and COTS climbing equipment. Whether operating at maritime depth, in a desert dust storm, or on the side of a remote cliff, the APA-5 brings new capability in a powerful, lightweight package.

Atlas Devices' ascenders has a product range with diverse capability and size.

Learn more: rebs.no



APA - 4



APA - 5



MAGNETIC CLIMBING SYSTEM (MCS)

An extremely powerful magnetic climbing system that easily supports the weight of one fully equipped operator. The system consists of a pair of lever-operated magnetic shoes and hand grips for climbing on ferromagnetic surfaces.

It works equally well for urban and maritime climbing of steel structures, and can be used from a submerged approach or from boat to boat. The system can provide access to ships and structures where hook and climb is not possible, and can even be used by divers to board a ship from the sea.

Learn more: rebs.no

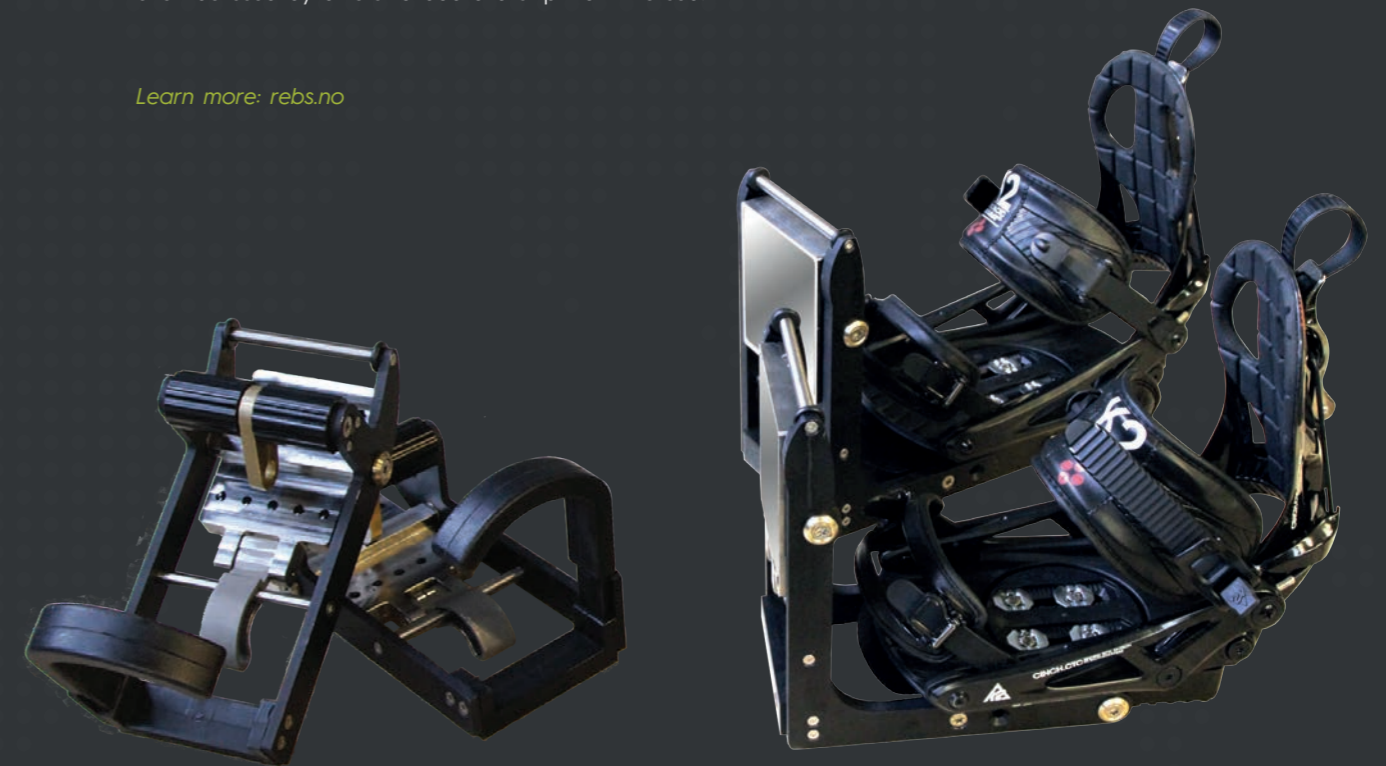



SCUBA TUBE

The Scuba Tube provides an easy and efficient way of transporting equipment safely and dry under water.

It has two ports that can be used to route cables or wires through the lid, and that way keep electronics and batteries dry. It is available in different lengths to suit different transportation needs. A modular design lets you combine sections to your capacity needs.



The Scuba Tube is rated for maximum 100 m depth.

Learn more: rebs.no

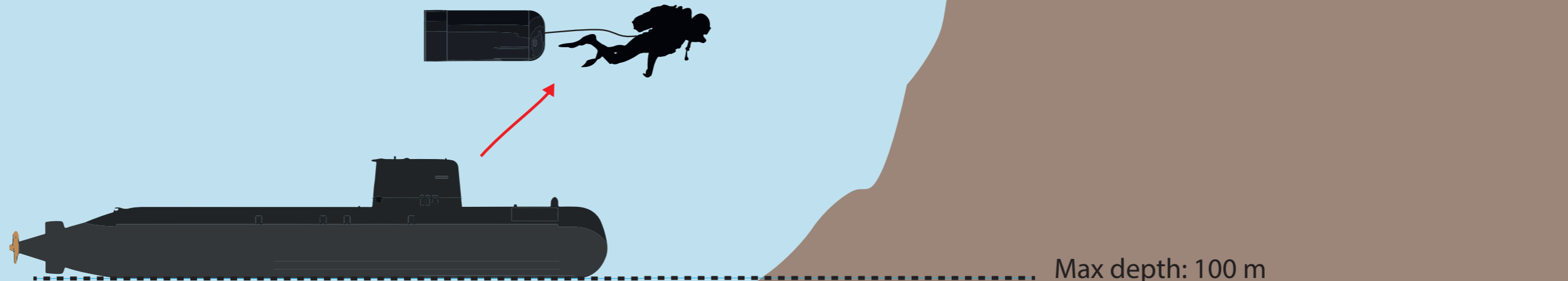

Max depth: 100 m

TACTICAL ACCESS RAMP

REBS Tactical Access Ramp, or T.A.R. for short, is the ideal ultra rapid entry solution when multiple operators are needed.

T.A.R. improves upon the proven concept of boarding ramps. Featuring light weight construction, and improved visibility during transport. Offering unmatched speed for multiple operators, while maintaining full control of both hands to carry weapons or other equipment.

T.A.R. is one of the only systems light enough, with low enough front-axle load to be legally operated on EU roads.

The ramp is accessible from inside, via the roof hatch.

Learn more: rebs.no

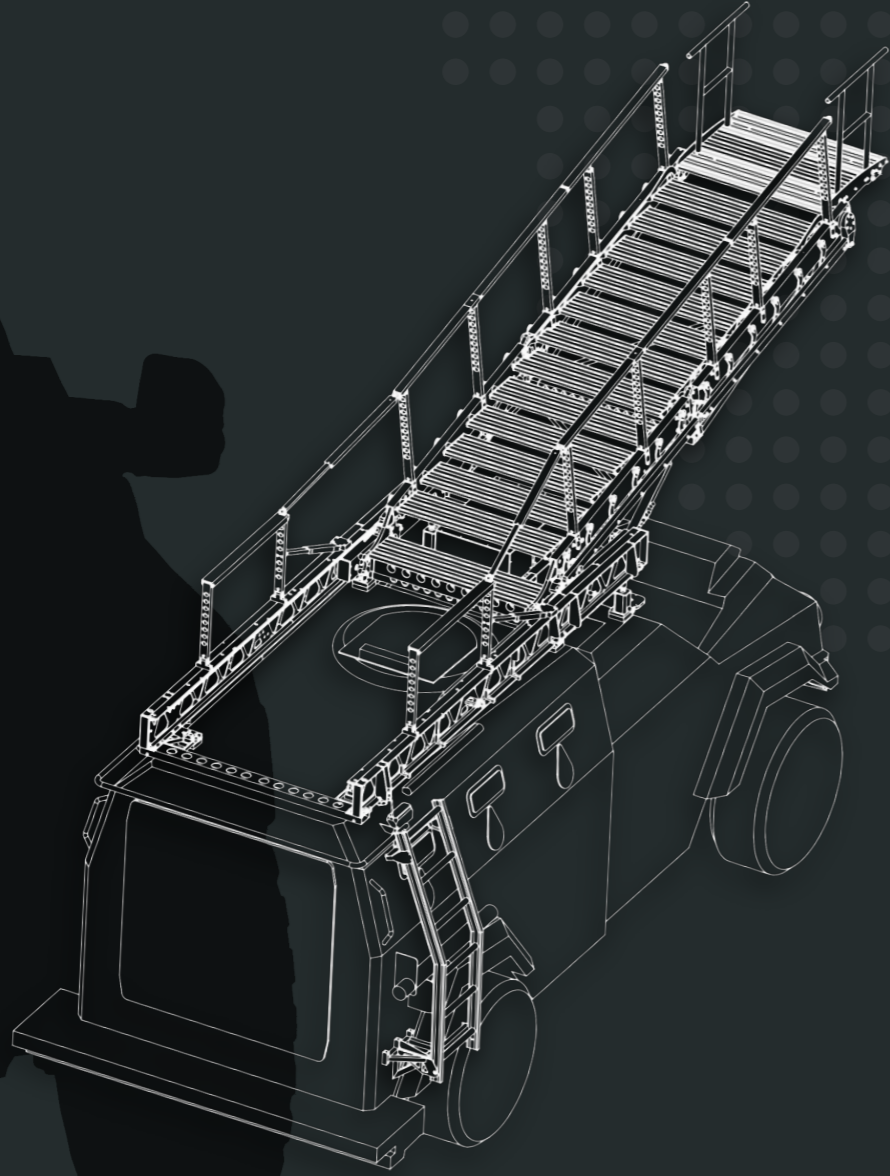

VALUES

HIGH STRENGTH

HIGH SPEED

LIGHT WEIGHT

LOW EXPOSURE

REBS

TABLE OF CONTENTS

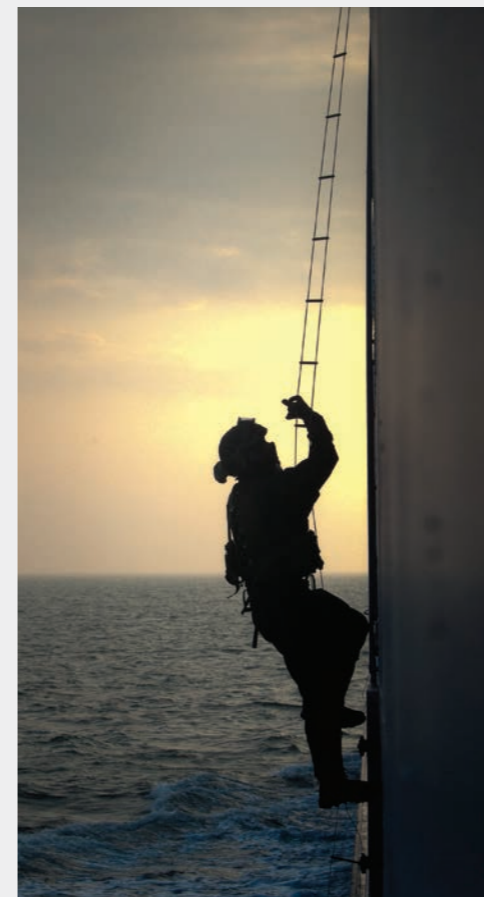

Introduction	5
Ladders	6
Ultralight Pole Ladder (UPL)	9
Carbon Multi Ladder (CML)	11
Full range of ladders	13
Hooks	14
Poles	16
SKYPOLE	19
Launchers	21
Ascenders	23
Magnetic climbing system (MCS)	25
Scuba tube	26
Tactical Access Ramp (T.A.R.)	29
Versatile product range	30
Reach chart	32

The users of REBS products aim to minimize exposure. We strive to make our products safer, stronger, lighter and faster than any other products in order to maximize the operational performance of our users.

VERSATILE PRODUCT RANGE

The users of REBS® products have their biggest enemy in exposure. We aim to make our products safer, stronger, lighter and faster than any other products in order to maximize the operational performance of our users. Our products allows our users to minimize the level of exposure and thereby reduce their operational risk.

REBS standard

Back in 2016 REBS published the first version of SOCES-2016 (Special Operation Climbing Standard). The standard sets requirements to strength-, design- and environmental- requirements and is a guide for designers, users and purchasers. The lack of relevant military and civil standards inspired us to create SOCES. It combines SO-requirements with operational- and technical limitations, based on years of experience with Rapid Entering and Boarding Systems (REBS).

The standard is open, to beshared to anyone with interest for the subject. Our scope is to make safer VA operations and to beable to compare similar systems to each other, and to create a common tests and understanding.

The standard is regularly improved so any comments or improvements is welcome.

REBS Training Modules

Basic (1-4 days)

The REBS Tailored Basic Maritime Interdiction Course (1-4 days) is designed to get the teams quickly up to speed on the tactical implementation of high-end boarding equipment.

Advanced (5 days – 10 weeks modular training course)

The REBS Tailored Advanced Training Course is a complete modular Maritime Interdiction or Counter Terrorism interdictions training course with all assets including HeloOps and Special Operations Craft.

All REBS courses are designed and conducted by world leading specialist in counter terrorism and maritime interdiction. Contact us for information and quote.

Maintenance and Safety Training

In additional to tactical training we offer product specific maintenance training on all REBS products.

Service and Recertification

To maintain climbing safety and safety with regards to high pressure products, such as the launcher, we recommend that all products is subject to service and recertification every 2 years. Such recertification will also renew the product warranty.

REACH CHART

www.rebs.no

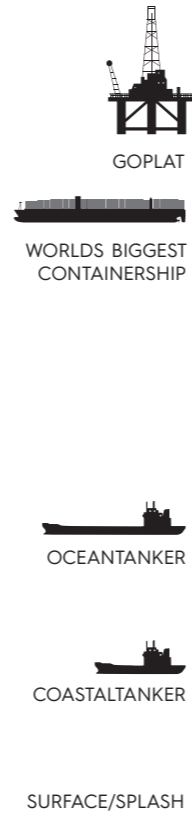

REACH CHART

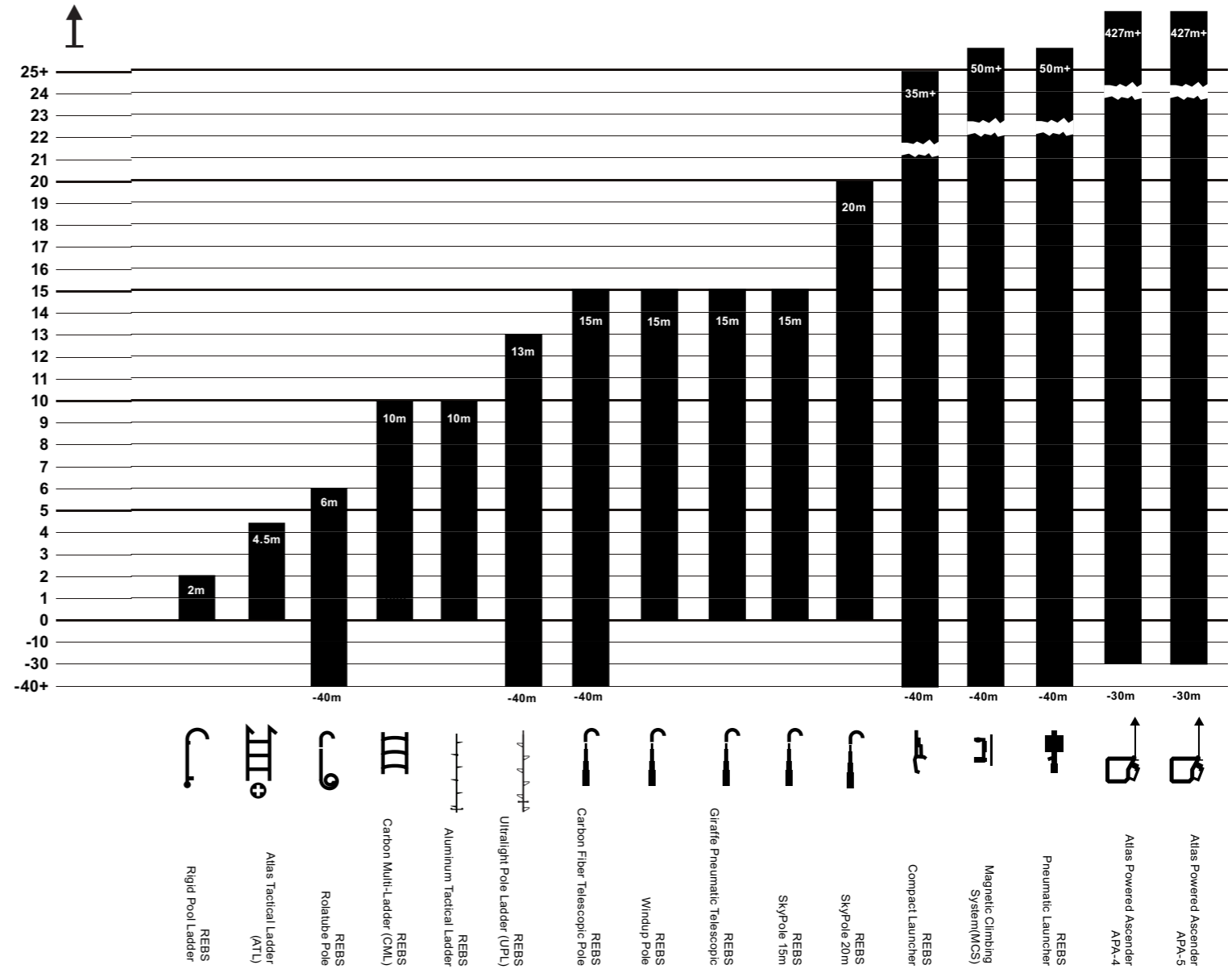

GENERAL CATEGORY GUIDELINE

Rigid Ladder 0-4 m. Section Ladder 2-13 m. Pole/Hook 3-20 m. Launcher 10-50 m. Ascender 5-500 m.

REBS